

# ADAPTERS, IN-SERIES

## 2.4mm

### DC - 50 GHz



MODELS: 5148, 5149 & 5150

#### SPECIFICATIONS:

##### Electrical:

Frequency Range \_\_\_\_\_ DC - 50 GHz  
VSWR  
DC - 18 GHz \_\_\_\_\_ 1.10:1 Max.  
18 - 26.5 GHz \_\_\_\_\_ 1.20:1 Max.  
26.5 - 50 GHz \_\_\_\_\_ 1.30:1 Max.  
Impedance \_\_\_\_\_ 50 Ohms  
Operating Temp Range \_\_\_\_\_ -65°C to +125°C

##### Mechanical:

Connectors \_\_\_\_\_ Passivated Stainless Steel  
Conductors \_\_\_\_\_ Gold Plated Beryllium Copper

Model Number: **5150**  
Male/Female Connectors

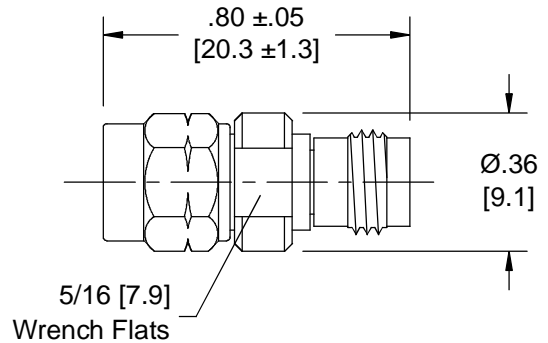

Model Number: **5149**  
Male/Male Connectors

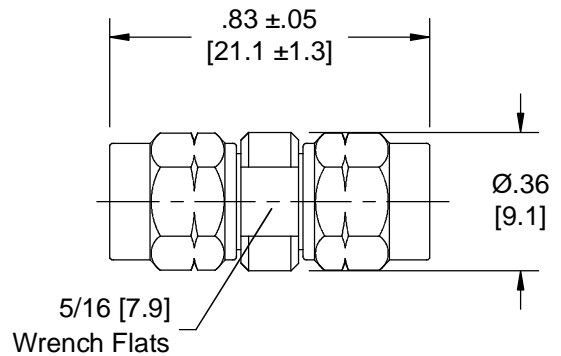

Model Number: **5148**  
Female/Female Connectors

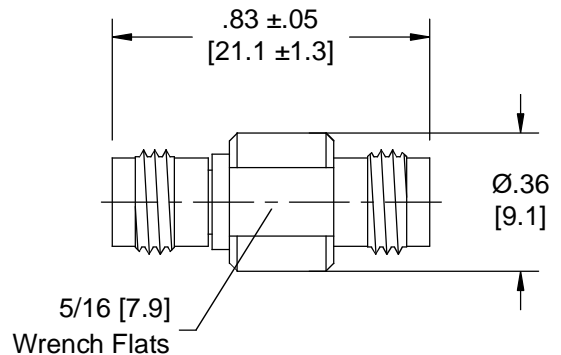

Note: Dimensions in Brackets are Expressed in Millimeters and are for Reference Only.  
Design specifications are subject to change without notice.  
Contact factory for technical specifications before purchasing or use.

5150; REV D