

# RF & MICROWAVE COMPONENTS & SUBSYSTEMS

apitech

ASK ABOUT OUR  
**NEW PRODUCTS!**  
+1 301-846-9222



## Weinschel Quick Reference Catalog

Digital & Programmable Attenuators | Butler Matrices |  
Programmable Attenuation, Phase Shifters & Switch Units | COTS  
Subsystems | High Reliability Attenuators | Low PIM Attenuators &  
Terminations | Medium & High Power Attenuators & Terminations |  
Conduction Cooled Attenuators & Terminations



# MMIC Digitally Switched Attenuator, Model 4205

Weinschel, a part of API Tech offers a series of MMIC Digital Attenuators operate from 0.2 to 6 GHz in a variety of attenuation ranges up to 95.5 dB in that operate steps as low as 0.25. These units can be controlled using either parallel TTL or USB interfaces.

- Ideal for Automated Test Equipment (ATE), WiMAX, 3G/4G, LTE, WiFi Fading Simulators, Engineering/Production Test Lab environments
- Excellent Solid-state Repeatability & Performance
- Uninterrupted RF when changing attenuation levels
- Ruggedized Construction



Model Number	Frequency Range (GHz)	Attenuation Range (dB)	Step Size (dB)	Insertion Loss, Max. (dB)	Maximum SWR <sup>1</sup>	Connector Type	Average Power
4205-31.5	0.2-6.0	0-31.5	0.5	3.0 - 4.0*	1.50-1.70*	SMA	+23 dBm
4205-63.5		0-63.5	0.25	4.5 - 6.0*	1.60-1.80*		
4205-95.5		0-95.5	0.5	6.5 - 8.0*	1.60-2.10*		

\*Varies with frequency.

## Control Configuration

Units are supplied with both parallel TTL and USB 2.0 interfaces. The mode of operation is determined by the source of DC power to the unit. NOTE: Do not simultaneously connect DC power to the TTL connector while the USB is connected.

**USING TTL CONTROL:** Each unit is supplied with a mating 10 pin connector (Amp 746285-1). Refer to Physical Dimensions for mating connector pin/wiring details. Two pins are specified for supply voltage and ground. The remaining pins will accept TTL control signals to activate or deactivate a particular attenuation cell. A TTL high will energize a cell to the high attenuation state, whereas a TTL low will maintain a cell in its zero attenuation state.

**USING USB CONFIGURATION:** The USB interface is compatible with standard USB 2.0 interfaces. In USB mode, DC power to the attenuator is provided by the host USB connection. The attenuator operates as a USB CDC device and accepts simple ASCII text commands. This allows the unit to be controlled from any system capable of sending data via a standard COM port-style interface.

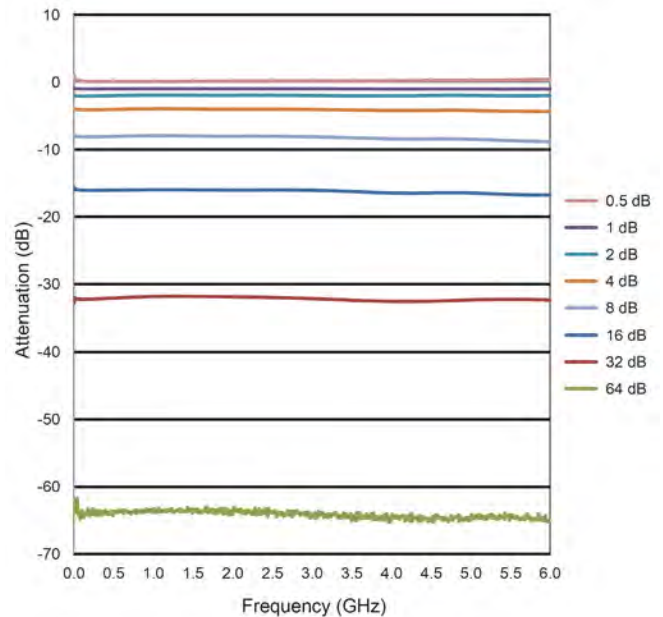

Attenuation Performance Plot





## Control Software Included

APItech Weinschel LabVIEW™ based USB Control Center Software can be used in conjunction with the operation of this Series of digital attenuators. The control center software will allow the user to setup, control and perform test and measurements using these digital attenuators over a standard USB 2.0 communication interface.



## Physical Dimensions

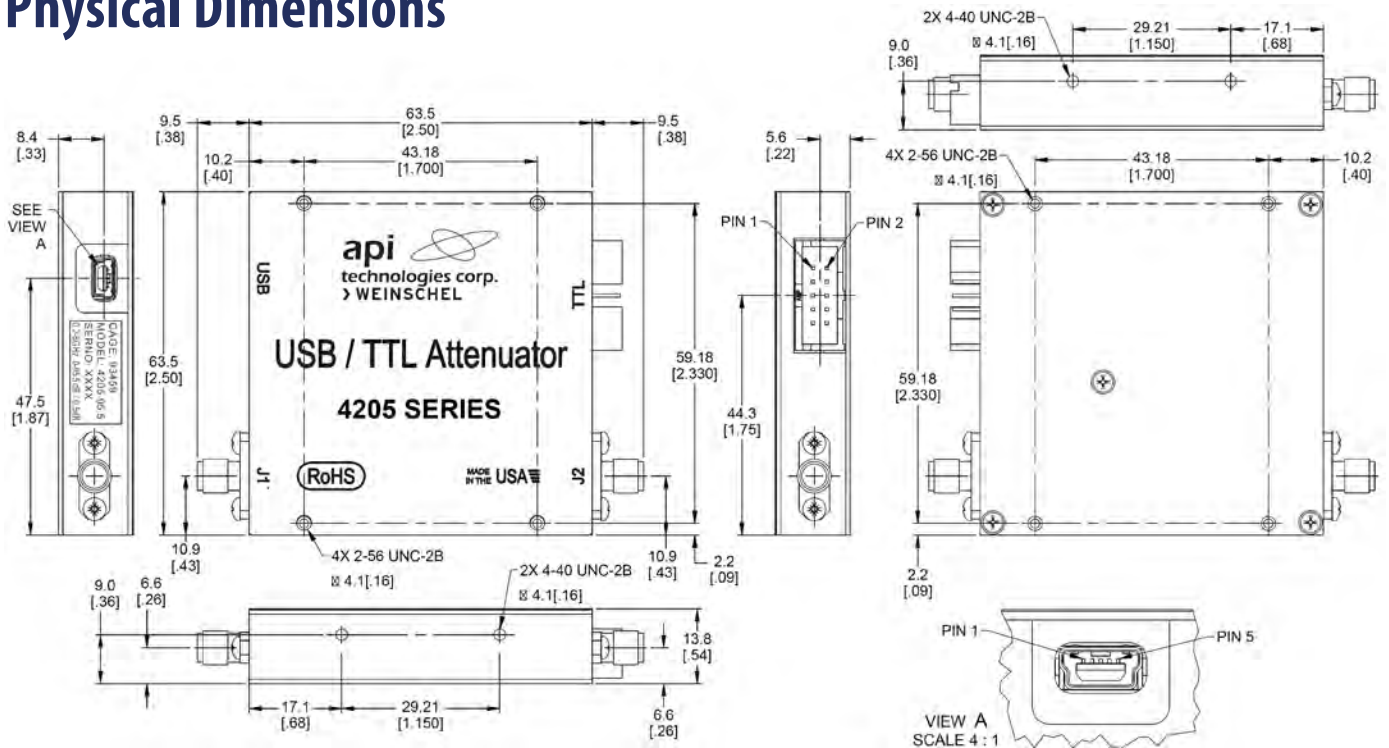

**NOTE:** All dimensions are given in mm (inches).



## Dual Band 4x4 Butler Matrix, Model 8401

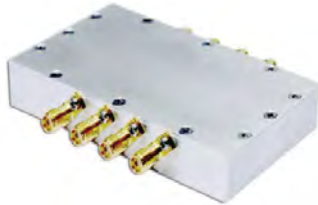

- Ideal for your Lab Testing/Calibration Setups and subsystem applications
- Operating Frequencies: 2.4 to 6.0 GHz
- Compact Module Design with SMA female connectors
- Inputs are isolated from each other
- VSWR: 1.5:1 Typical, 1.6:1 Maximum
- Insertion Loss: 8 dB Typical, 10 dB Maximum
- Isolation: 18 dB Typical, 15 dB Maximum
- Operation Temperature Range: -20°C to +70°C
- Custom and other configurations available

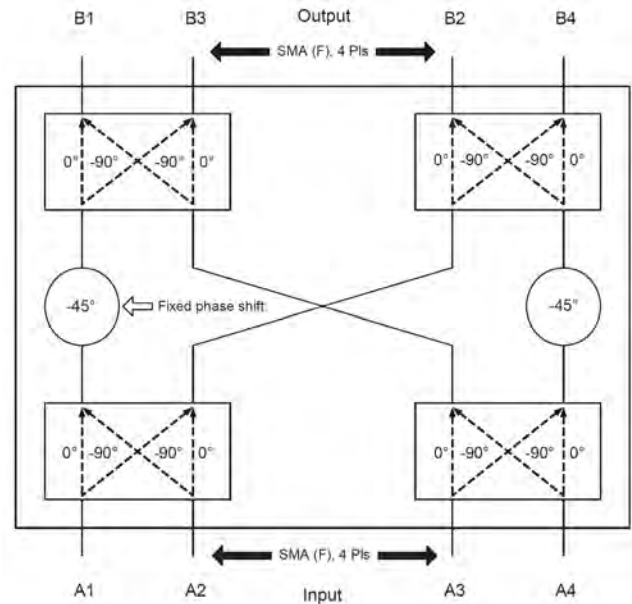

## Digital Switch, Model 4284



Weinschel, a part of APITech offers a series of MMIC Digital Attenuators operate from 0.2 to 6 GHz in a variety of attenuation ranges up to 95.5 dB in that operate steps as low as 0.25. These units can be controlled using either parallel TTL or USB interfaces.

- Ideal for Automated Test Equipment (ATE), WiMAX, LTE, WiFi, 3G/4G Fading Simulators, Engineering/ Production Test Lab environments
- Excellent Solid-state Repeatability & Performance
- Uninterrupted RF when changing attenuation levels
- Unselected ports are internally terminated with a 50 ohm load
- Switching Speed: 1µsec maximum (TTL)  
5 msec typical (USB)
- Control Software Included
- Ruggedized Construction

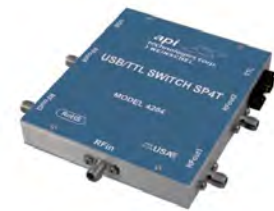

Model Number	Switch Type	Frequency Range (GHz)	Isolation Min. Typ. Max.	Insertion Loss, Min. (dB)	Maximum SWR <sup>1</sup>	Connector Type	Average Power
4284	SP4T	0.1-6.0	0.1-30: 60 55	3.0-4.5	1.50:1	SMA	1
			3.0-5.0: 48 42				
			5.0-6.0: 38 30				





## Control Configuration

Units are supplied with both parallel-TTL and USB 2.0 interfaces. The mode of operation is determined by the source of DC power to the unit. NOTE: Do not simultaneously connect DC power to the TTL connector while the USB is connected.

**USING TTL CONTROL:** Each unit is supplied with a mating 10 pin connector (Amp 746285-1). Refer to Physical Dimensions for mating connector pin/wiring details. Two pins are specified for supply voltage and ground. The remaining pins will accept TTL control signals to activate or deactivate a particular switch position.

**USING USB CONFIGURATION:** The USB interface is compatible with standard USB 2.0 interfaces. In USB mode, DC power to the switch is provided by the host USB connection. The switch operates as a USB CDC device and accepts simple ASCII text commands. This allows the unit to be controlled from any system capable of sending data via a standard COM port-style interface.

## Control Software Included

APITech Weinschel LabVIEW™ based USB Control Center Software (UCS) can also be used in the operation of this series of digital switches. The UCS will allow the user to setup, control and perform test and measurements using these digital switches over a standard USB 2.0 communication interface.



## Physical Dimensions

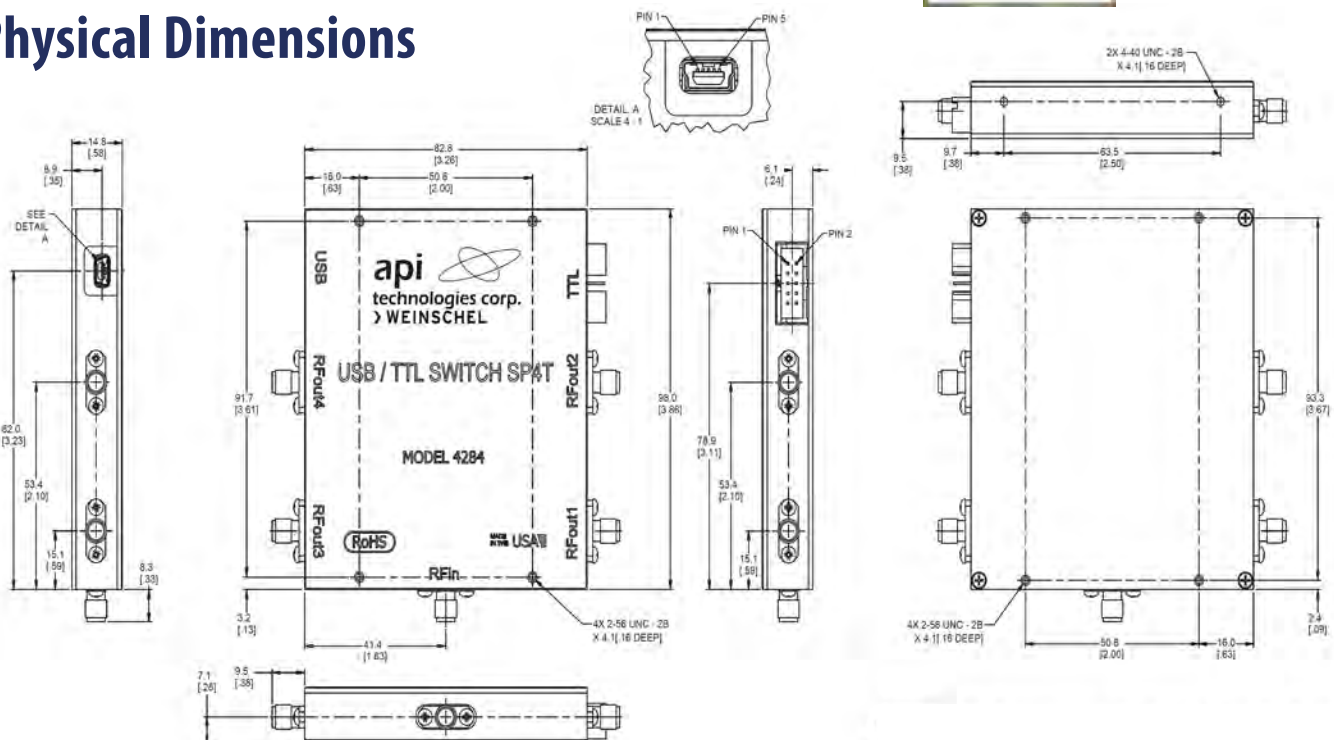

**NOTE:** All dimensions are given in mm (inches).



## 75 Ω Programmable Attenuators

Model 3456 Series 75 Ω Programmable Step Attenuators are designed for use in automatic test equipment and OEM systems operating in the DC to 3 GHz frequency range. Each cell contains a double-pole, double-throw relay that provides a zero path or attenuated path for the RF signal.

- Cost Effective design for Wireless/Cable Applications
- Custom Configurations including bus controlled attenuator subsystems



Model Number	Frequency Range (GHz)	Attenuation Range (dB)	Step Size (dB)	Insertion Loss, Max. (dB)	Maximum SWR	Connector Type	Average Power (Watts)	Peak Power (Watts)
3456-63	DC-3.0	0-63	1	2.10-3.30*	1.45-1.50*	SMA	1	50

\*Varies with frequency.

## 6 GHz Programmable Attenuators & Phase Shifters

Ideal for Wireless/Test Applications Ideal for Wireless/Test Applications

- High Frequency range to 6 GHz
- Selection of Attenuation Range & Step Sizes
- High Quality Construction & Connectors
- Optional TTL Interface for easy Subsystem Integration
- Special Configurations Available Upon Request



### Programmable Attenuators

Model Number	Frequency Range (GHz)	Attenuation Range (dB)	Step Size (dB)	Insertion Loss, Max. (dB)	Maximum SWR	Connector Type	Average Power (Watts)	Peak Power (Watts)
3404-15	DC-6.0	0-15	1	2.60	1.30-1.45*	SMA	1	50
3404-55		0-55	5	2.60				
3404-70		0-70	10	2.60				
3404T-15	DC-6.0	0-15	1	2.60	1.30-1.45*	SMA	1	50
3404T-55		0-55	5	2.60				
3404T-70		0-70	10	2.60				
3409-127	DC-6.0	0-127	1	3.8-5.8*	1.40-1.55*	SMA	1	50

\*Varies with frequency.



## Programmable Phase Shifters

Model Number	Frequency Range (GHz)	Phase Shift Range (°)	Insertion dB Max. (Any Phase State)	Insertion Loss Variation	Insertion Phase (°)	Max. SWR <sup>1</sup>	Power Rating (Watts)	Connector Type
984-1	DC-6.0	From 0° @ DC to 630° in 10° steps @ 6 GHz (Normally linear with frequency)	2.5 @ 3 GHz 4.3 @ 6 GHz	± 0.5 dB Typical	2,700° Typical @ 6 GHz	1.50-1.60*	1	SMA

\*Varies with frequency.

## Programmable Attenuator Units, Models 8320, 8321 & 8331



Provides a flexible, easy to program, low cost solution for your bench test/calibration setups and subsystem applications. This Series of Programmable Attenuator Units represent a new streamlined approach in programmable attenuation for bench test and subsystem applications. Standard 8320 and 8321 Series designs house and control various Weinschel Programmable Attenuator Models (3200-XE, 3400, 150T, and 4200 Series) via front panel controls, Ethernet, USB and Serial communications interfaces. A GPIB (IEEE-488) interface is also available as an option.

The 8320 series are single or up to 4 channel configurations housed in half rack enclosures. The 8321 series are multi-channel configurations housed in 19 inch enclosures and can be configured for up to 12 attenuation channels. Both series can be configured for front or rear and through options.

Model 8331 Series offers a lower cost solution for automated bench test and subsystem applications. Most 8331 Series are multi-channel configurations where RF signal is routed through either the front or rear mounted ports. This series can be configured for up to 12 independent channels of attenuation and can be controlled via Ethernet, USB and Serial communications interfaces.

APITech Weinschel also provides custom subsystems where a variety of test configurations can be incorporated within a single unit. Contact us with your specialized needs.



Model 8321



Model 8320



Model 8331



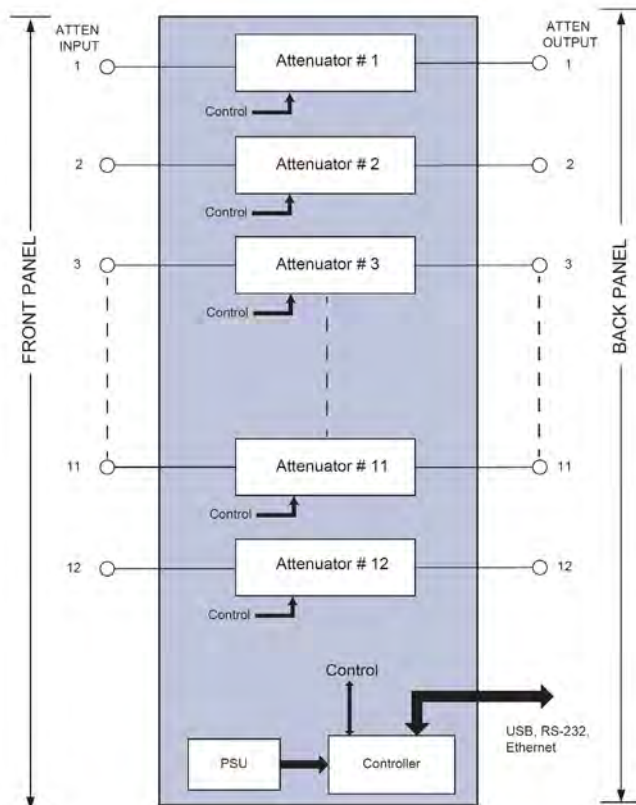

Simplified 12 Channel Block Diagram

## Control Software Included

APItech Weinschel LabVIEW™ based Attenuator Control Center Software (ACCS) can be used in conjunction with the operation of this series of programmable attenuator units and allows the user to setup, control and perform test and measurements over standard communication interfaces such as USB, Ethernet, or RS-232.

## Model Number Configuration Matrix

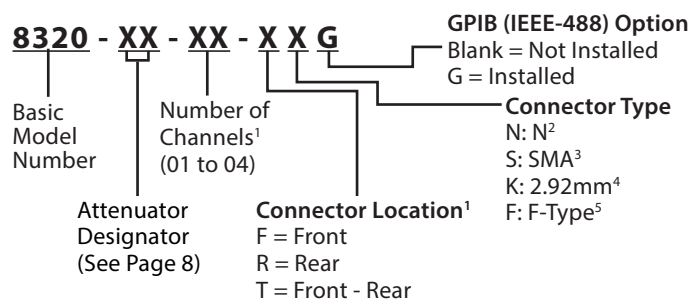

Example: 8320-M3-02-TS

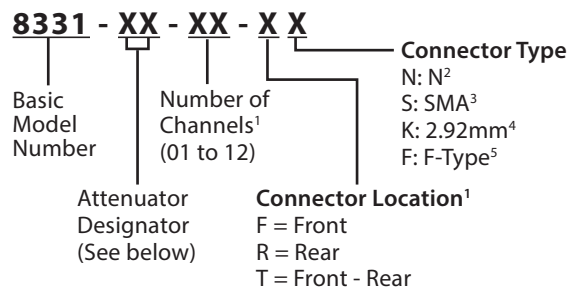

Example: 8331-M3-09-TS

1. **8320**: Up to 4 channels total except for up to 2 channels for option F & R (Front or Rear), up to 2 channels for option C & D (150T & 152T Series), 1 channel only for option C7 & D5, up to 2 channels for option E3  
**8321 & 8331**: Up to 12 channels total except for up to 6 channels for option F & R (Front or Rear), up to 10 channels for option C & D (150T & 152T Series), up to 5 channels for option C7 & D5, up to 6 channels for option E3
2. Not available for option D, E & F (152T, 156 & 3456 Series)
3. Not available for option E & F (156 & 3456 Series)
4. Only for option E (156 Series)
5. Only for option F (3456 Series)





## Attenuator Designations & Specifications

Electro-Mechanical								
Frequency Range	Attenuator Designation	Model	Range (dB)	Step Size (dB)	Insertion Loss (maximum)	VSWR (maximum)	<input type="checkbox"/> RoHS	
DC-3 GHz	A	1	3205-1E	70	10	3.75 dB	1.4	
		2	3205-2E	55	5	3.75 dB	1.4	
		3	3205-3E	1.5	0.1	3.75 dB	1.4	
		4	3201-1E	31	1	4.00 dB	1.4	
		5	3206-1E	63	1	4.25 dB	1.4	
		6	3200-1E	127	1	5.25 dB	1.4	
		7	3200-2E	63.75	0.25	5.25 dB	1.4	
		8	3209-1E	64.5	0.1	6.50 dB	1.5	
DC-6 GHz	B	1	3404-15	15	1	3.50 dB	1.55	
		2	3404-55	55	5	3.50 dB	1.55	
		3	3404-70	70	10	3.50 dB	1.55	
		4	3406-55	55	1	4.50 dB	1.55	
		5	3408-55.75	55.75	0.25	6.00 dB	1.55	
		6	3408-103	103	1	6.00 dB	1.55	✓
		7	3409-127	127	1	6.50 dB	1.55	
DC-18 GHz	C	1	150T-70	70	10	3.25 dB	1.75	✓
		2	150T-15	15	1	3.50 dB	1.95	✓
		3	150T-75	75	5	3.50 dB	1.95	✓
		4	150T-110	110	10	3.50 dB	1.95	✓
		5	150T-31	31	1	3.75 dB	1.95	✓
		6	150T-62	62	2	3.75 dB	1.95	✓
		7	150T-15 & 150T-110	125	1	5.50 dB	1.95	✓
DC-26.5 GHz	D	1	152AT-70	70	10	4.75 dB	1.95	✓
		2	152T-15	15	1	5.00 dB	1.95	✓
		3	152T-75	75	5	5.00 dB	1.95	✓
		4	152T-90	90	10	5.00 dB	1.95	✓
		5	152T-90 & 152T-15	105	1	8.00 dB	1.95	✓
DC-40 GHz	E	1	156-11	11	1	5.00 dB	2.00	✓
		2	156-90	90	10	5.00 dB	2.00	✓
		3	156-11 & 156-90	101	1	7.00 dB	2.00	✓
DC-3 GHz (75Ω)	F	1	3456-63	63	1	4.50 dB	1.70	✓

**RoHS** compliance dependent on attenuator installed. Some attenuators are NOT compliant.



Solid State								
Frequency Range	Attenuator Designation	Model	Range (dB)	Step Size (dB)	Insertion Loss (maximum)	VSWR (maximum)	RoHS	
0.8 to 2.5/3 GHz	J	1	4226-63	63	1	4.75 dB	1.6	
		2	4228-63.75	63.75	0.25	6.00 dB	1.6	
		3	4228-103	103	1	6.00 dB	1.6	
0.01 to 2.5 GHz	K	1	4238-63.75	63.75	0.25	10.00 dB	1.75	
		2	4238-103	103	1	10.00 dB	1.75	
0.01 to 2.5 GHz	L	1	4246-63	63	1	11.00 dB	2.0	
		2	4248-63.75	63.75	0.25	14.00 dB	2.0	
		3	4248-103	103	1	14.00 dB	2.0	
0.2 to 6 GHz	M	1	4205-31.5	31.5	0.5	4.00 dB	1.8	✓
		2	4205-63.5	63.5	0.5	6.00 dB	1.8	✓
		3	4205-95.5	95.5	0.5	8.50 dB	2.0	✓

✓ **RoHS** compliance dependent on attenuator installed. Some attenuators are NOT compliant.

## Physical Dimensions

Front Option:

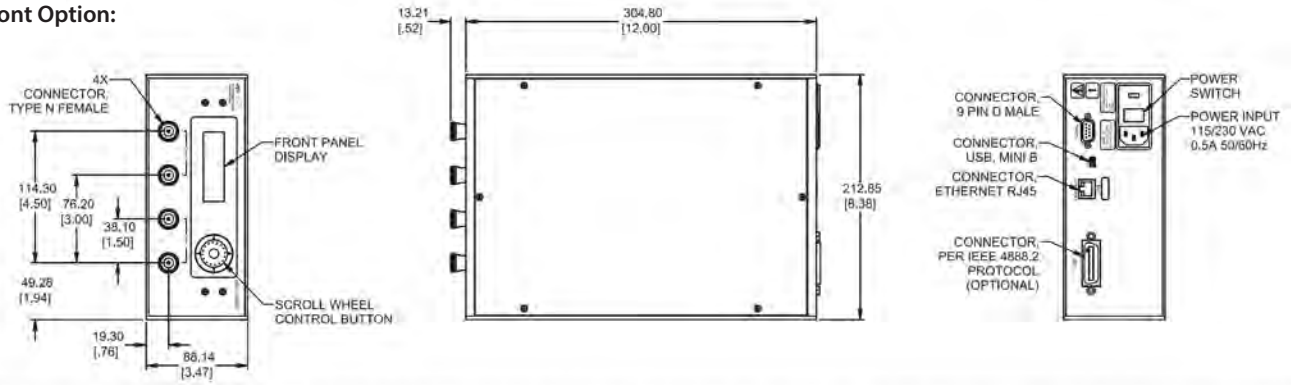

Rear Option:

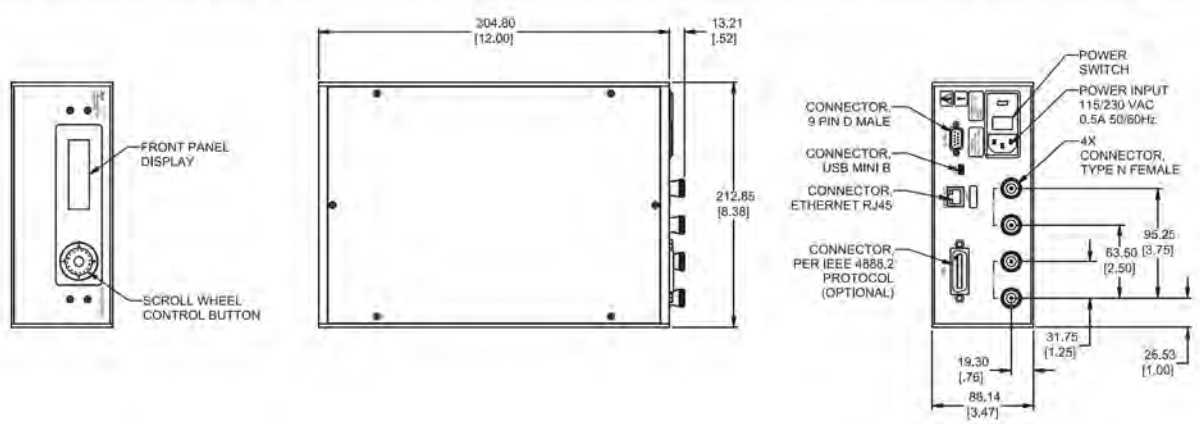





**Standard 19 in Rack Unit up to 12 channels:**

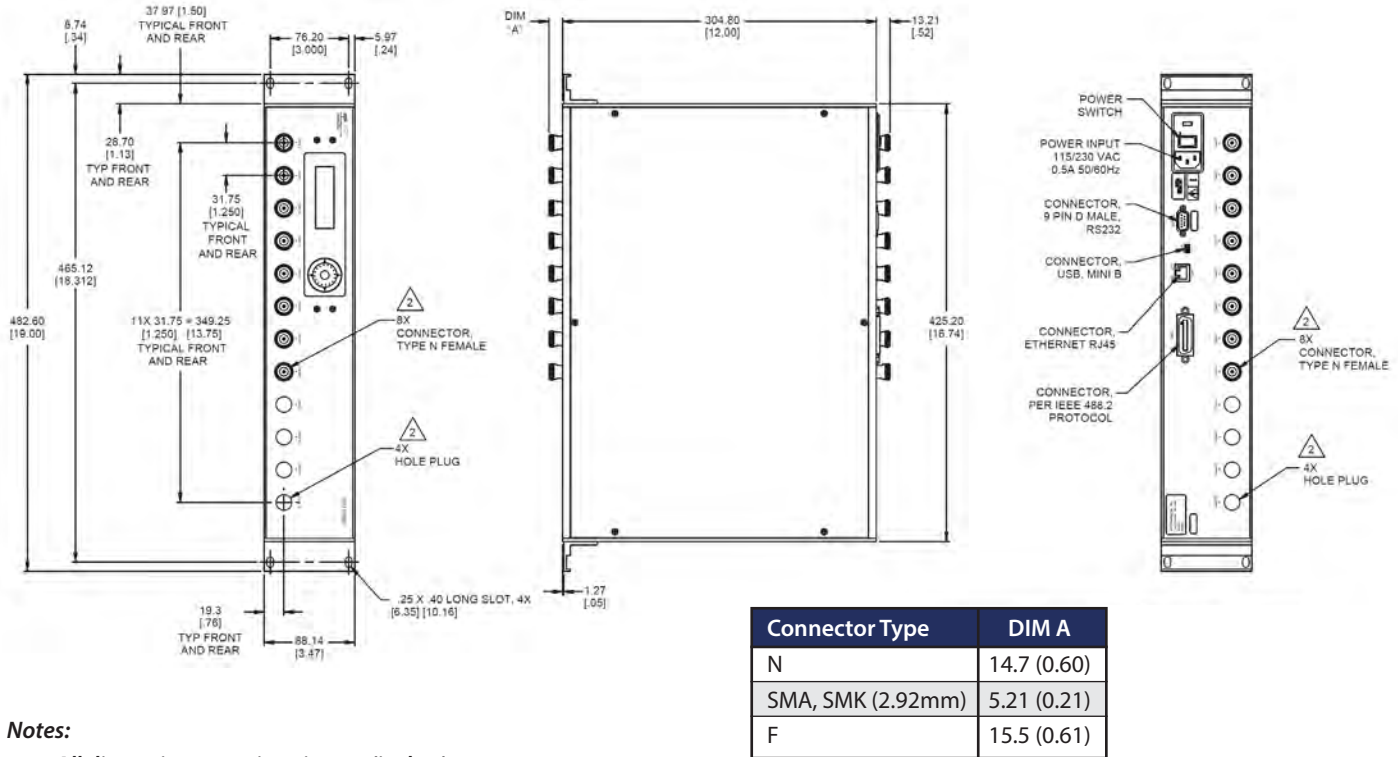

**Notes:**

1. All dimensions are given in mm (inches).
2. Connectors and hole plugs are installed as required and determined by number of channel in unit. 2 channel shown for Model 8320 and 8 channel unit shown for 8321.
3. Connector location (Front/Rear) may vary depending on Model ordered.

## 8304-5, RF Switch Subsystem (Simplifies Mobile Radio Testing)

Weinschel Model 8304-5 RF Switching System is part of an automated test set-up for various types of commercial and military radios. The difference in the test set up and configuration between different types of radios will be the control interconnect cables used.

The block diagram below shows the RF Switch Subsystem which is designed to control and test up to 5 radios at a time. This sub-system acts as an interface and is connected to a Model 3901 Digital Radio Test Set (customer provided) to enable the total system to automatically connect signals to 5 radios. The RF signals are routed through an internal electro-mechanical switch. The Digital Radio Test Set is used as the controller, signal stimulus and measurement instrument.



All switching selection occurs via the USB control port located on the rear panel of the Model 8304-5. The RF Switching System is an RF subsystem that utilizes an internal Micro Computer to provide control of the switches and relays via the USB to serial interface.

**Features**

- DC - 2 GHz Frequency Range
- 50 Ohm Impedance
- 5 Radio Interfaces
- RS-232 Control



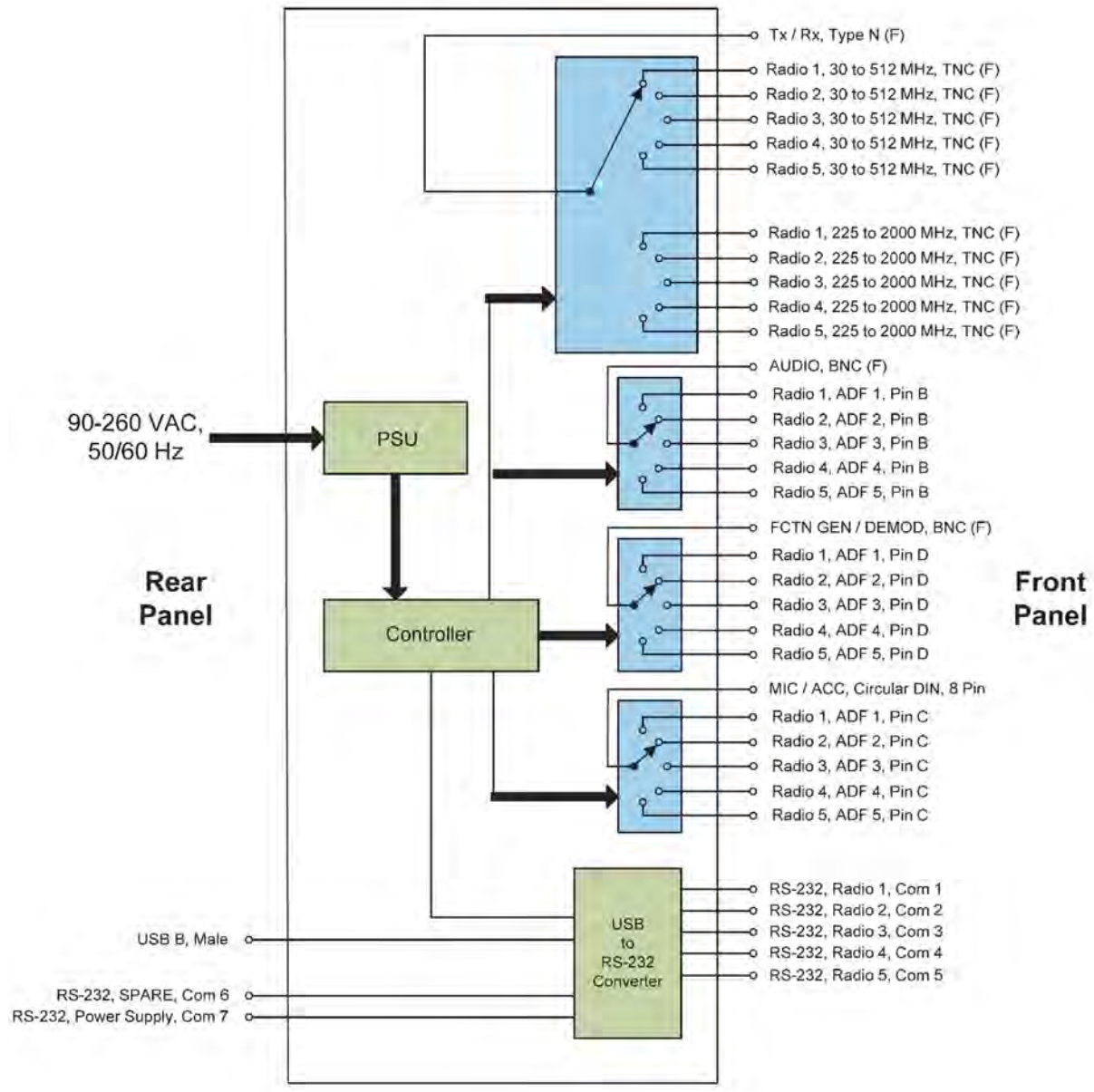

Simplified Block Diagram





## Physical Dimensions

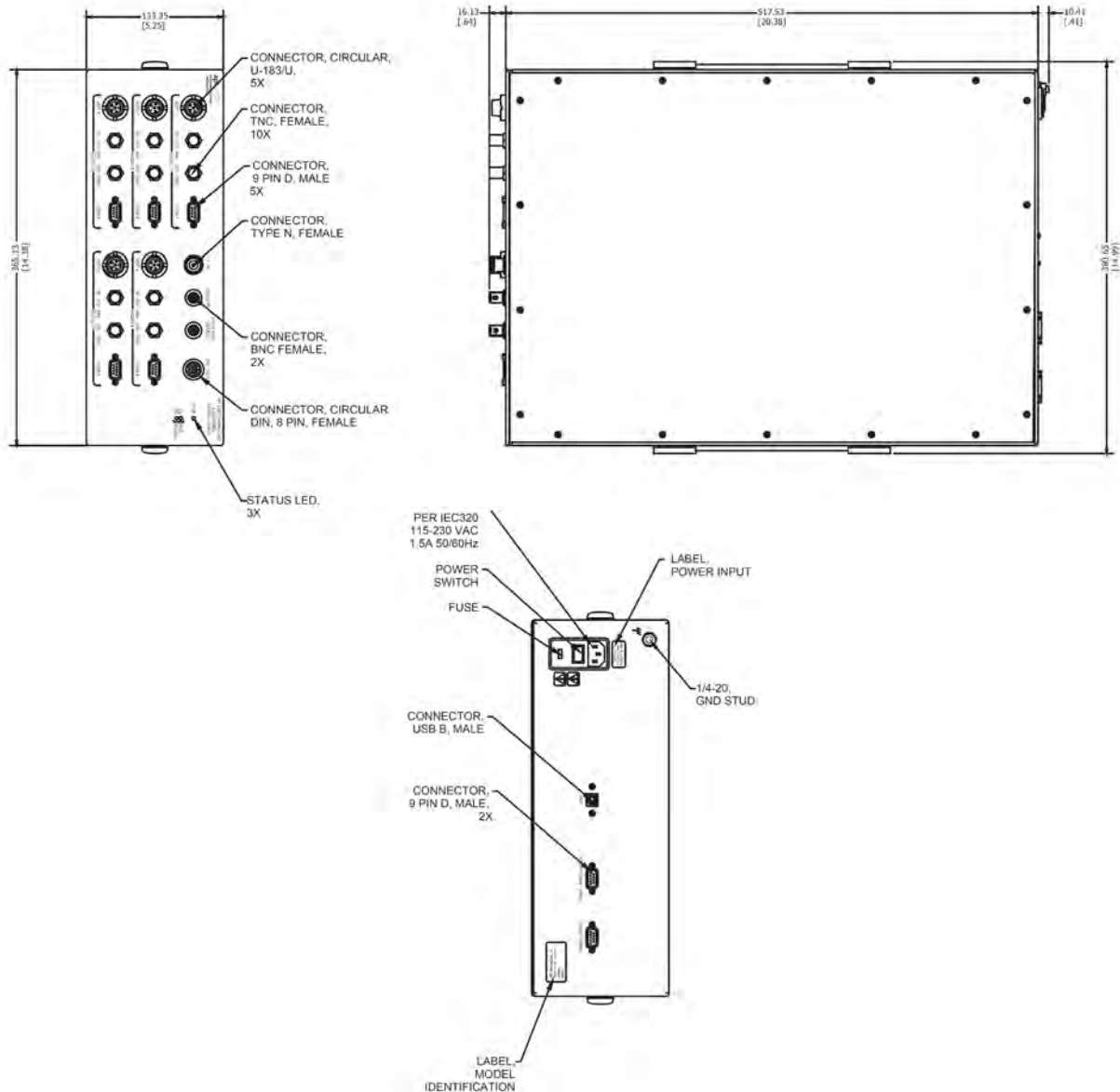

**NOTE:** All dimensions are given in mm (inches) and are maximum, unless otherwise specified.

**EXPORT CONTROL:** This product is controlled for export under the International Traffic in Arms Regulations (ITAR). A license from the U.S. Department of State is required prior to the export of this product from the United States.

**EXPORT WARNING:** Military and space products are controlled for export under the International Traffic in Arms Regulations (ITAR) and may not be sold or proposed or offered for sale to certain countries. (See ITAR 126.1 for complete information.)



# Programmable Attenuation Profile Simulator Unit, Model 8334



Weinschel 8334 Series of Attenuation Profile Simulators provide multi-channel high-speed attenuation control with synchronous output update capability. The unit allow for programming of up to 128K (131072) attenuation data points per attenuator and sweeping through those data points at user-programmable intervals from 50  $\mu$ sec to 1 sec per point. The system provides for non-volatile storage of up to four data point tables which may be later recalled under user control. Status and control TTL signals are availabl for external monitoring and sweep control via a rear-panel DE9 connector.

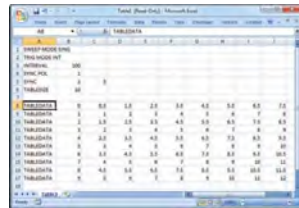

The 8334 Series are multi-channel configurations housed in 19 inch enclosures and can be configured for up to 8 attenuation simulator channels with front, rear or through (front to rear) RF signal routing.

Weinschel also provides custom subsystems where a variety of test configurations can be incorporated within a single unit. Contact us with your specialized needs.

## Features

- Programmable attenuation update rates from 50  $\mu$ sec. per point to 1 second per point in 50  $\mu$ sec. intervals
- External TTL trigger (with programmable polarity) allows for synchronization with other external hardware
- Various TTL status outputs (Running, Programmable Sync. and Interval Update) for monitoring a profile
- Supplied with industry standard communication interfaces:
  - RS-232 (Serial)
  - Ethernet Control (10/100 BaseT)
  - USB 2.0
- Rack Configurable: Rack ears are supplied



## Applications

Applications for the 8334 Series include:

- Simulate path loss on each channel or mobility scenarios between a handset and multiple base stations
- Create arbitrary, synchronous attenuation profiles with timing skews of <10 nsec. between channels to replicate precision fading and handover scenarios
- Generate coherent, multi-channel pulsed RF outputs for a given attenuation level

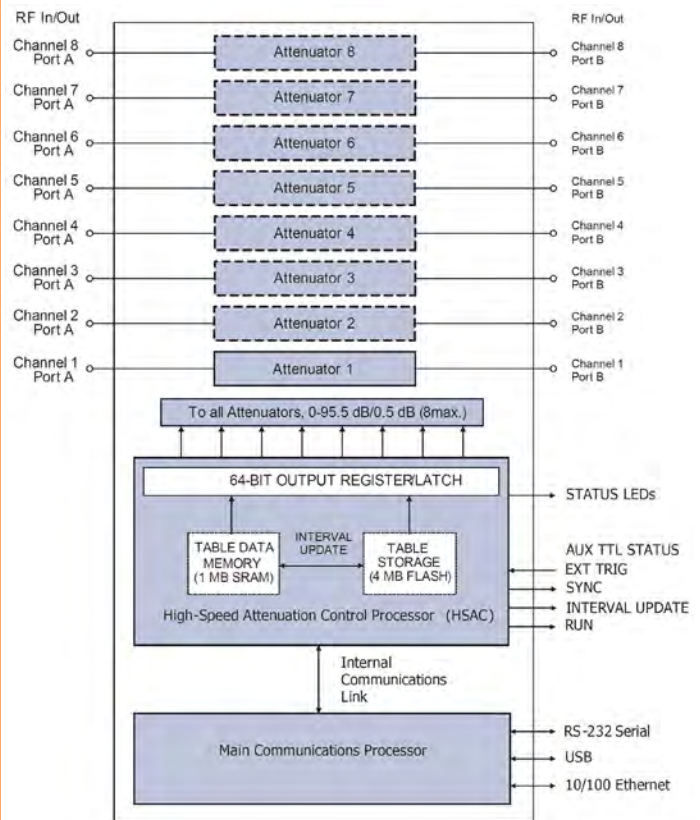

Simplified 8 Channel Block Diagram





## Physical Dimensions

Standard 19 in Rack Unit up to 8 channels:

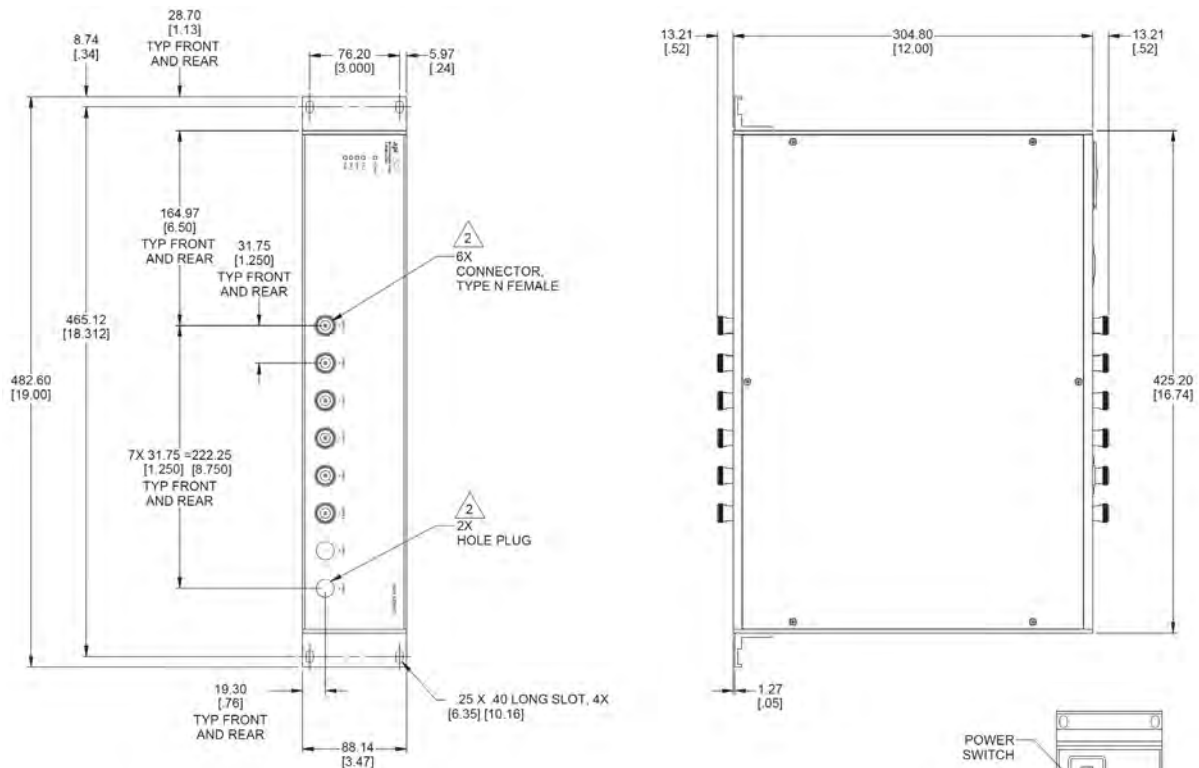

### Notes:

1. All dimensions are given in mm (inches).
2. Connectors and hole plugs are installed as required and determined by number of channel in unit. Six channel unit shown.
3. Connector location (Front/Rear) may vary depending on Model ordered.

## Model Number Configuration Matrix

**8334 - M3 - XX - X N**

Basic Model Number

Number of Channels (01 to 08)

Attenuator Designator

Connector Location

F = Front\*  
R = Rear\*  
T = Thru

Connector Type  
N = N Female

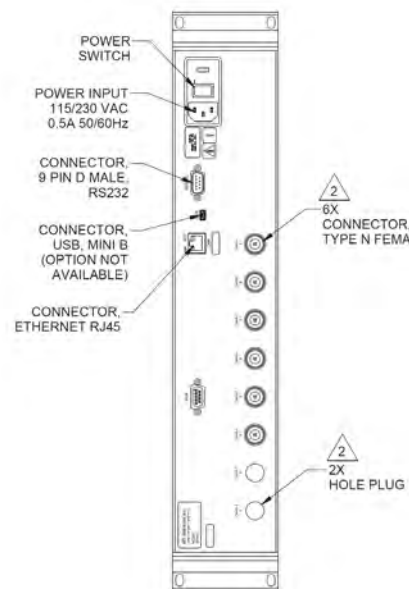

\* up to 6 Channel units available for option F & R.



Solid State								
Frequency Range	Attenuator Designation		Attenuation Model	Range (dB)	Step Size (dB)	Insertion Loss (maximum)	VSWR (maximum)	<input type="checkbox"/> RoHS
0.2 to 6 GHz	M	3	4205-95.5	95.5	0.5	8.50 dB	2.0	<input checked="" type="checkbox"/>

**RoHS** compliance dependent on attenuator installed. Some attenuators are NOT compliant.

## Model 8351, High Power Fixed Attenuator Unit RoHS

### Internal Temperature Monitoring/Reporting

The Weinschel Model 8351 Series of High Power Fixed Attenuator Units offers a compact, rack mount solution to monitor up to 6 channels of Weinschel High Power Fixed Attenuators for bench testing, subsystem, and system applications. The standard Model 8351 Series designs operate over the DC to 6 GHz frequency range, with power handling up to 400 watts C.W. The Model 8351 Series features Weinschel Conduction Cooled (flat pack) Attenuators, mounted on an internal heat sink and are cooled with 2 automatic, variable speed fans based upon internal temperature monitoring. This series can be configured with front mounted Type N connectors (IN/OUT) for up to 3 channels, or front to rear Type N connectors for up to 6 Channels.

LabVIEW™ based Attenuator Monitor Software is included for the monitoring of the internal power sensors via USB 2.0 or RS-232 communication interfaces.

Weinschel also provides custom configurations where multiple dB values / high power requirements can be incorporated within a single unit. Contact us with your specialized needs.

### Features

- Sensors indicate the maximum allowed input power into each channel
- Thermal monitoring of each channel reported through USB 2.0 and Serial communication interface
- Multi-Channel fixed attenuation paths (up to 6 channels)
- Extremely low VSWR
- Frequency Range from DC to 6 GHz minimum
- Power Handling up to 400 watts C.W. per channel
- Standard communication interfaces:
  - USB 2.0
  - RS-232 (Serial)
- 3 light LED Front Panel status indicator
- LabView based Attenuator Monitor Software included
- Rack Configurable - Rack mount ears are supplied for a standard 19" rack configuration

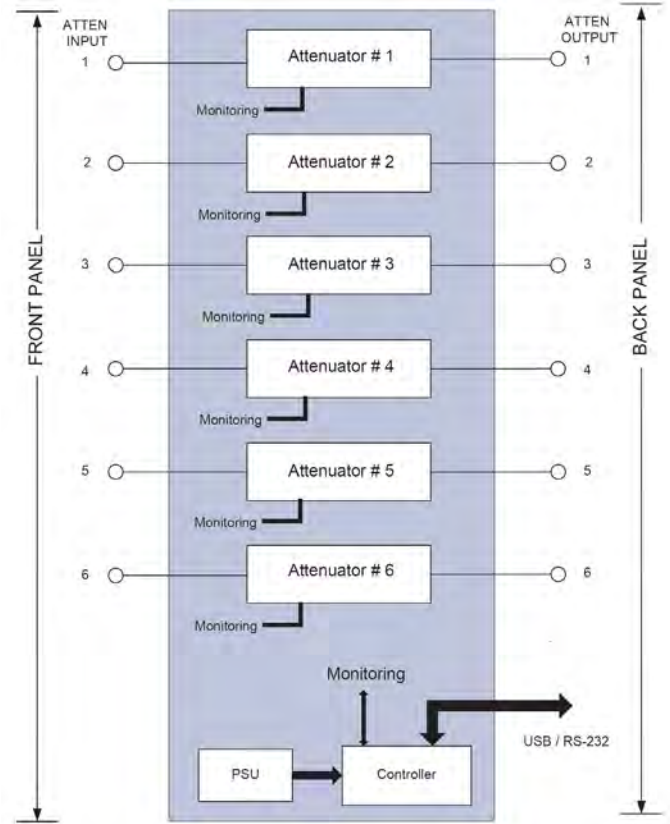

Simplified 6 Channel Block Diagram





## Applications

Applications for the 8334 Series include:

- 4G LTE Base Station Testing
- Distributed Antenna Systems (DAS)
- Military Radio Testing
- High Power Amplifier Testing



## Model Number Configuration Matrix

**8351 - A XX - X - X N**

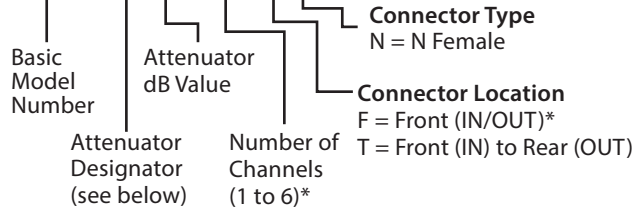

**Example:** 8351-A10-6-TN

\* Up to 3 Channels for Option F (Front)

## Physical Dimensions

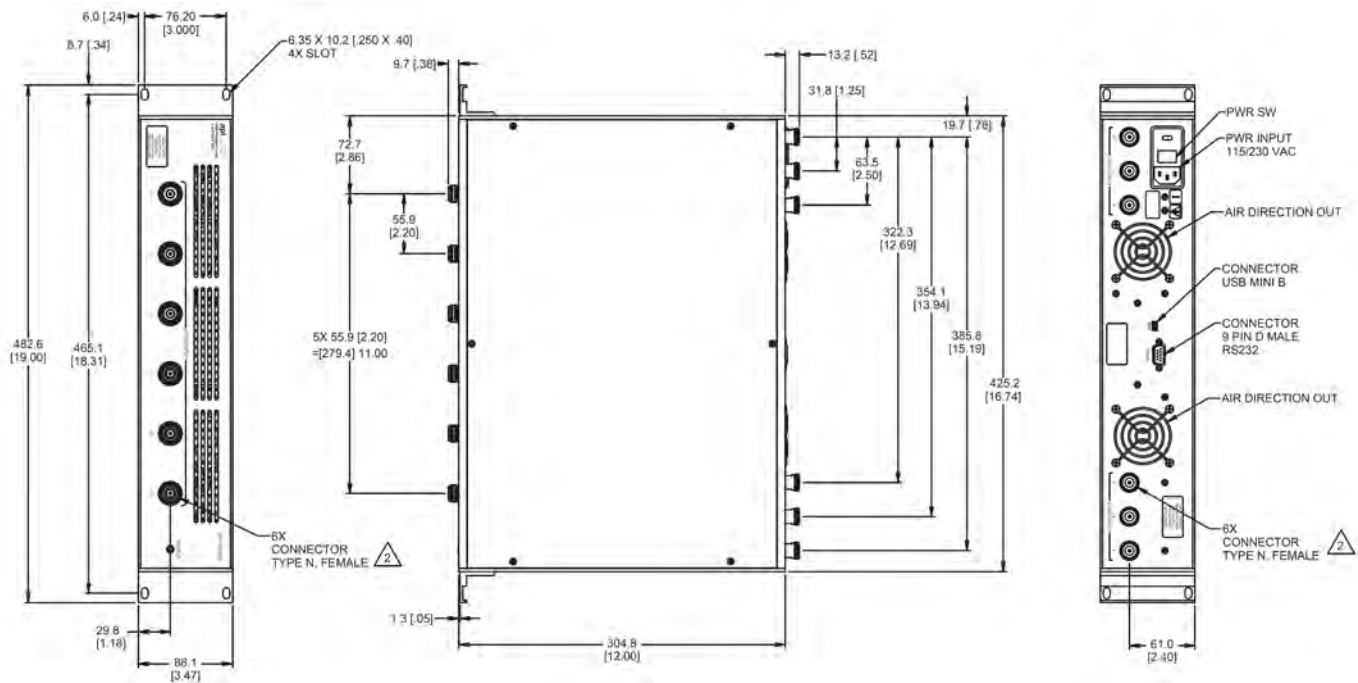

### Notes:

1. All dimensions are given in mm (inches).
2. Connectors and hole plugs are installed as required and are determined by the number of channels in the unit. 6 channel shown.
3. Connector location (Front/Rear) may vary depending upon the Model ordered.



## Attenuator Designations & Specifications

Channel Specifications										
Frequency Range	Attenuator Designation	Attenuator Model	Attenuation (dB)	Deviation (±dB)	VSWR (Max.)		VSWR Out (maximum)	Max. Power** (Watt)	☐ RoHS	
					2.5 GHz	2.5-6 GHz				
DC-6 GHz	A	10	268-10-33	10	1	1.1	1.15	1.35	100	
		20	268-20-33	20	1	1.1	1.15	1.35	100	
		30	268-30-33	30	1	1.1	1.15	1.35	100	
		40	268-40-33	40	1	1.1	1.15	1.35	100	
DC-6 GHz	B	10	257-10-33	10	1	1.1	1.15	1.35	250	
		20	257-20-33	20	1	1.1	1.15	1.35	250	
		30	257-30-33	30	1	1.1	1.15	1.35	250	
		40	257-40-33	40	1	1.1	1.15	1.35	250	
DC-6 GHz	C	10	258-10-33	10	1.50	1.1	1.15	1.35	400	
		20	258-20-33	20	1.50	1.1	1.15	1.35	400	
		30	258-30-33	30	1.75	1.1	1.15	1.35	400	
		40	258-40-33	40	1.75	1.1	1.15	1.35	400	

**RoHS** compliance dependent on attenuator installed. Some attenuators are NOT compliant.

\*\* Maximum Input Power is derated in certain cases, depending upon the ambient temperature and the number of active channels.

## Programmable Phase Shifter Units, Models 8420 & 8421



Weinschel Model 8420 and 8421 Series represent a new streamlined approach in signal phase shift control for bench test and subsystem applications. This series is designed to house and control the new Weinschel Programmable Phase Shifter series via front panel controls, Ethernet, USB and Serial communications interfaces. A GPIB (IEEE-488) interface is also available as an option.

The 8420 series are single or dual channel configurations housed in half rack enclosures. The 8421 series are multi-channel configurations housed in 19 inch enclosures and can be configured for up to 12 channels. Both series can be configured for front or rear and through (front to rear) is only available for 8421 Series.

Weinschel also provides custom subsystems where a variety of test configurations can be incorporated within a single unit. Contact us with your specialized needs.



Model 8421



Model 8420



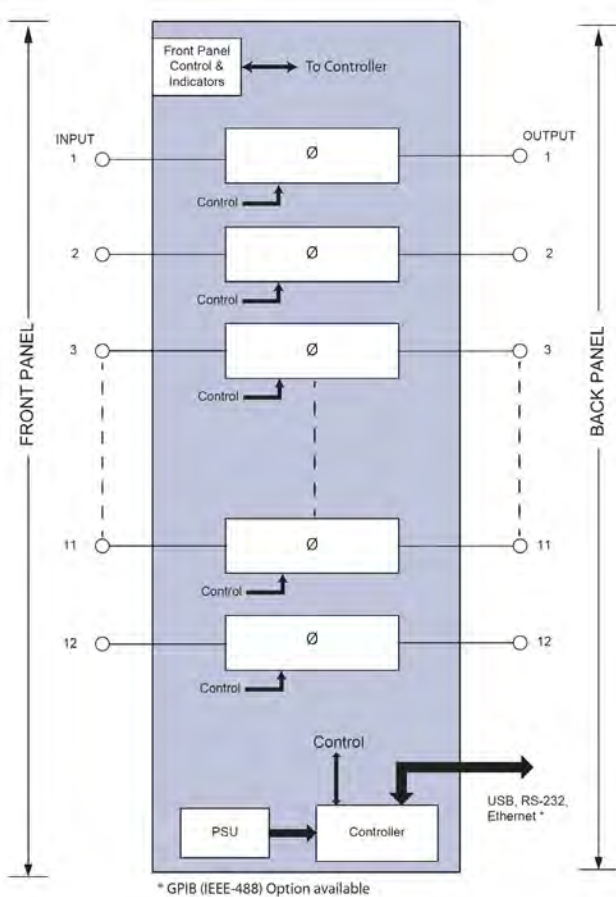

**Simplified 12 Channel Block Diagram**

## Control Software Included

Weinschel's LabVIEW™ based Control Center Software can be used in conjunction with the operation of this series of programmable phase shifter units and allows the user to set-up, control and perform test and measurements over standard communication interfaces such as RS-232, USB, Ethernet, or optional GPIB (IEEE-488).

## Model Number Configuration Matrix

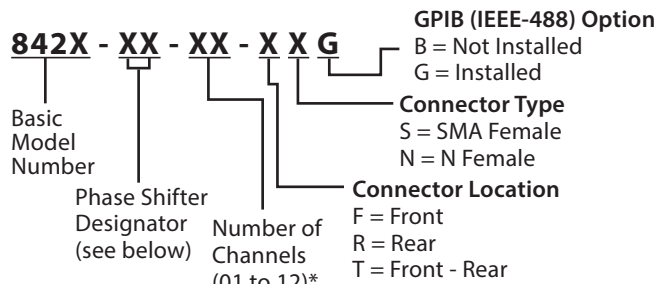

**Example:** 8421-A1-12-TS-G

\* Up to 2 Channels (8340) & 6 Channels 8341) for option F & R (Front or Rear)

Electro-mechanical								
Frequency Range	Phase Shifter Designation		Phase Shifter Model	Range (°)	Step Size (dB)	Insertion Loss (maximum)	VSWR (maximum)	RoHS
DC to 6 GHz	A	1	984-1	0 - 630	10°	6.0 dB	1.6	<input type="checkbox"/>

**RoHS** compliance dependent on attenuator installed. Some attenuators are NOT compliant.



# Physical Dimensions

Model 8420, Half Rack Unit, 1 or 2 channels:

Front Option:

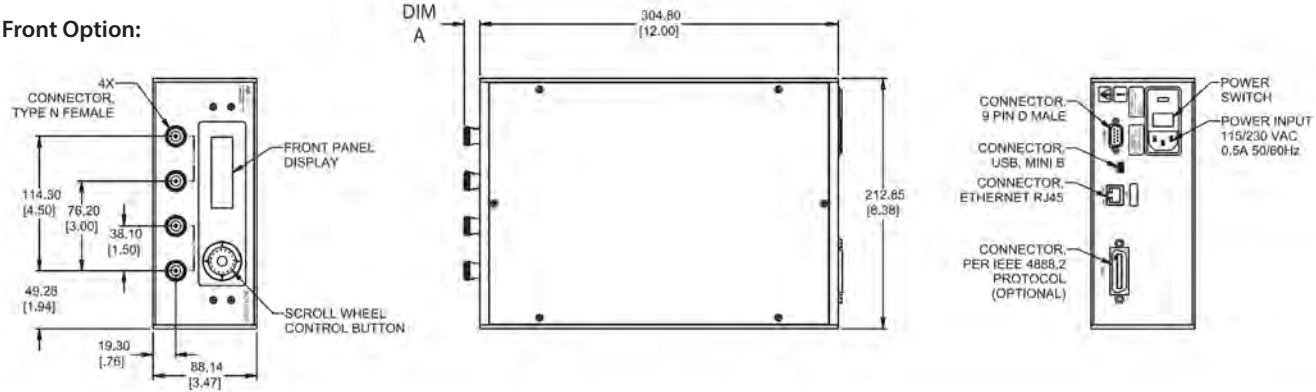

Rear Option:

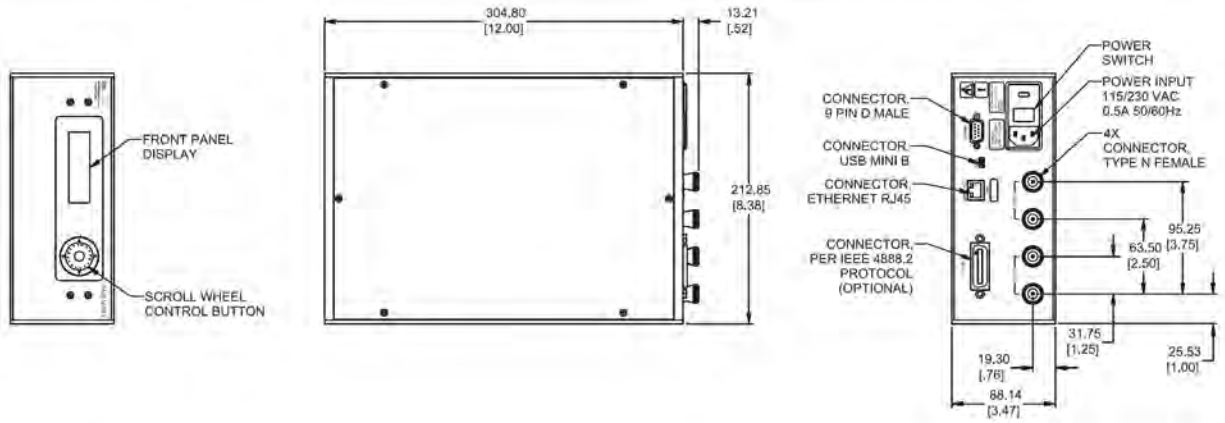





**Model 8421, Standard 19 in Rack Unit up to 12 channels:**

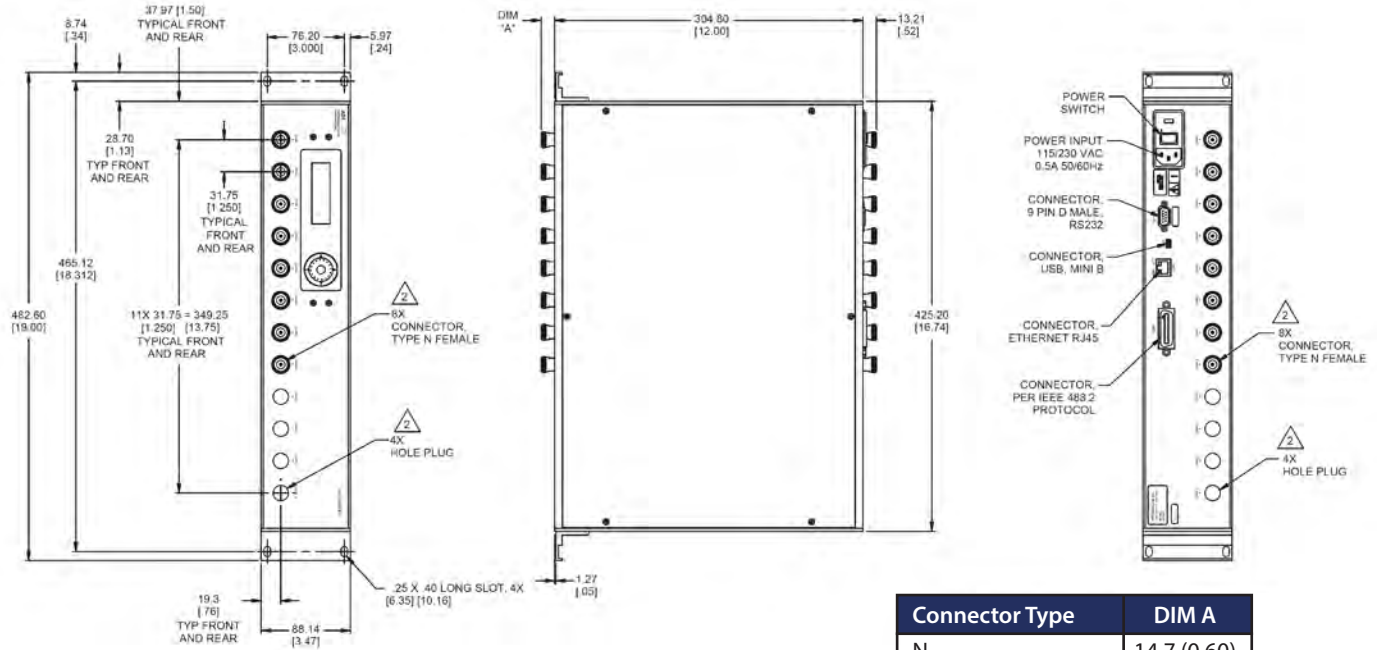

**Notes:**

1. All dimensions are given in mm (inches).
2. Connectors and hole plugs are installed as required and determined by number of channel in unit. 2 channel shown for Model 8420 and 8 channel unit shown for 8421.
3. Connector location (Front/Rear) may vary depending on Model ordered.

## Programmable Switch Unit, Model 8512



The Weinschel Model 8512 Series of Programmable Switch Units offer a compact, expandable, rack mount solution for a variety of test, subsystem, and system applications. The Model 8512 Series operates over the DC to 18/26.5 GHz frequency range, with SP3T to SP6T configurations with up to 14/6 switches respectively. Ethernet, USB, and RS-232 control interfaces are standard, along with LabVIEW™ based control software. A GPIB/IEEE-488 interface is also available as an option.

Using the Switch Control Center Software supplied with each unit, the user can quickly set up and operate the unit's switches independently, or using the Configure Virtual Switch option, create custom "tree" or "matrix" configurations by assigning input, output, and path labels as required.

Weinschel also provides custom configurations where a variety of configurations can be incorporated within a single unit. Please contact us with your specialized needs.





## Features

- Can be configured with up to 14 each, SP3T, SP4T, SP5T, or SP6T Switches
- Front panel local control and display make it ideal for lab and manual test environments
- Up to 26.5 GHz Operating Frequency Range
- Integrated Switched Cycle Counter
- Failsafe (break-before-make) & Latching (make-before-break) switching functionality available
- Easily expandable - additional switches can be quickly installed by the customer
- Low Insertion Loss and High Isolation
- Supplied with industry standard communication interfaces:
- Ethernet (10/100 BaseT)
- USB 2.0
- RS-232 (Serial)
- GPIB/IEEE-488 optional
- LabView™ based Switch Control Software included
- Compact 2 RU, 19" Rack Mount Configuration. Other configurations available

## Applications

- Wi-Fi, WiMax, 4G LTE Base Station Testing
- Signal routing from multiple instruments to single or multiple DUTs
- Production Testing - Multiple tests can be performed using the same test setup
- ATE and STE applications requiring configuration flexibility

## Model Number Configuration Matrix

**8512 - XX - XX - X G**

Basic Model Number

Switch Designator (see table)

Number of Switches Installed (01 to 14)\*

GPIB (IEEE-488) Option  
B = Not Installed  
G = Installed

Connector Location  
F = Front  
R = Rear

**Example:** 8512-A6-07-F

\*Up to 6 Channels for Option C

## Control Software Included

Weinschel LabVIEW™ based Switch Control Center Software (SCCS) is to be used in conjunction with the operation of the Weinschel 8512 series of programmable switch units. The SCCS will allow the user setup, control and perform tests and measurements using these programmable switch units over standard communication interfaces.

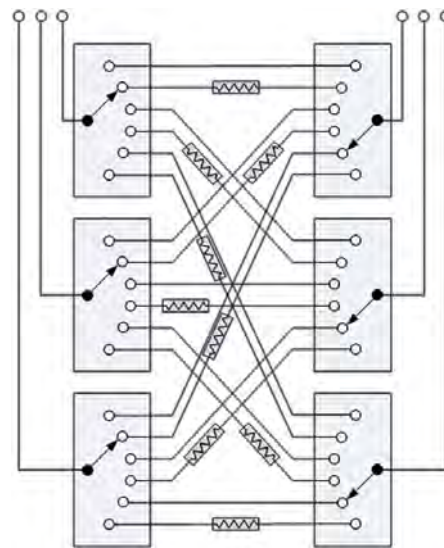

Redundant 3 x 3 matrix with fixed attenuators in the redundant paths as an example of an 8512-06-XX application.

Electro-mechanical			
Switching Description	Switch Designation	# of Positions	
DC-18 GHz, Failsafe to open, Make Before Break, SMA Female	A	3	SP3T
		4	SP4T
		5	SP5T
		6	SP6T
DC-18 GHz, Latching, Make Before Break, SMA Female	B	3	SP3T
		4	SP4T
		5	SP5T
		6	SP6T
DC-26.5 GHz, Failsafe to open, Break Before Make, SMA Female	C	3	SP3T
		4	SP4T
		5	SP5T
		6	SP6T





# Physical Dimensions

Options A & B:

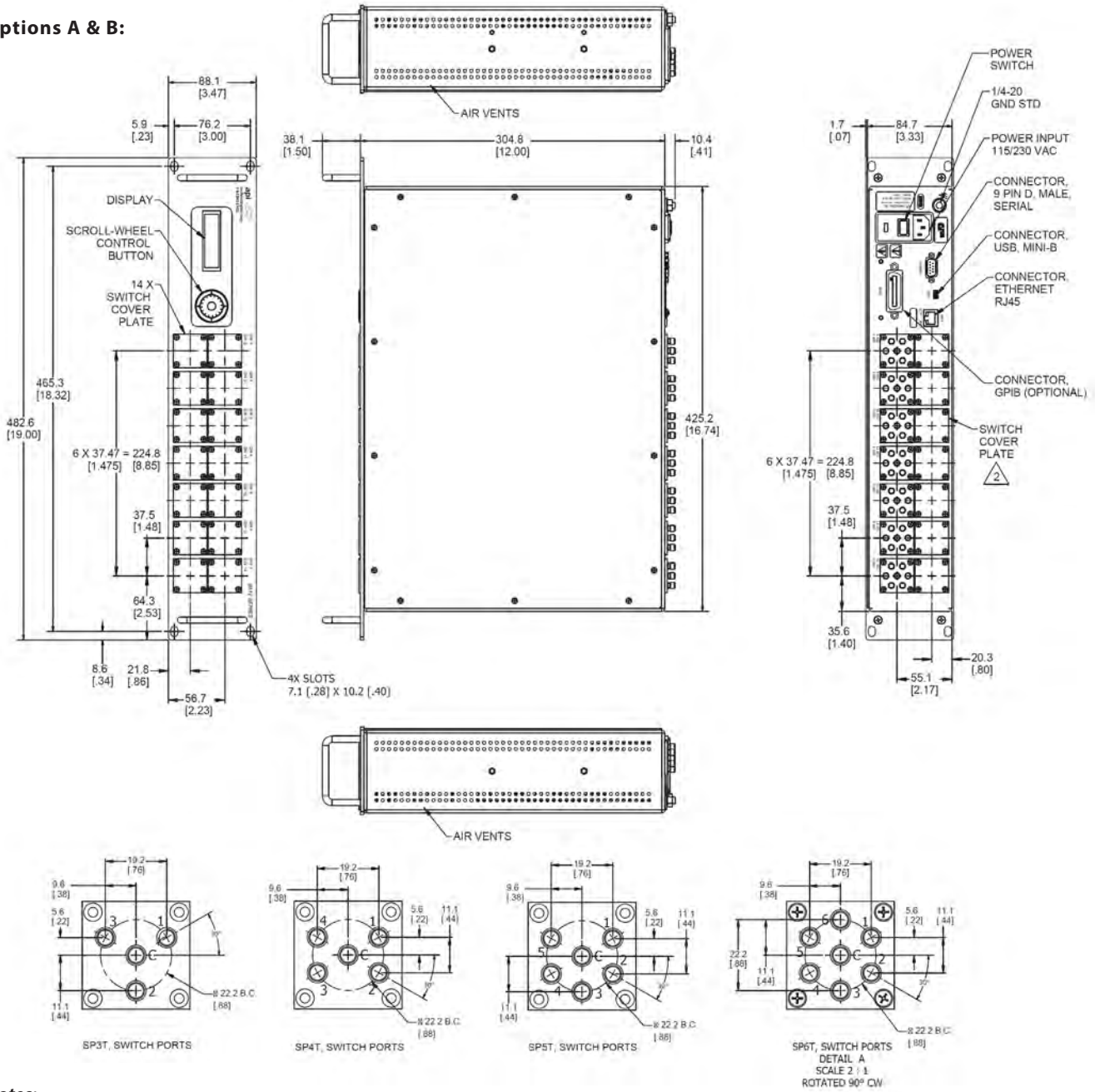

**Notes:**

1. All dimensions are given in mm (inches).
2. RF Switches and switch plates as required and determined by configuration. Seven switch unit configuration shown.



# Physical Dimensions

## Options C:

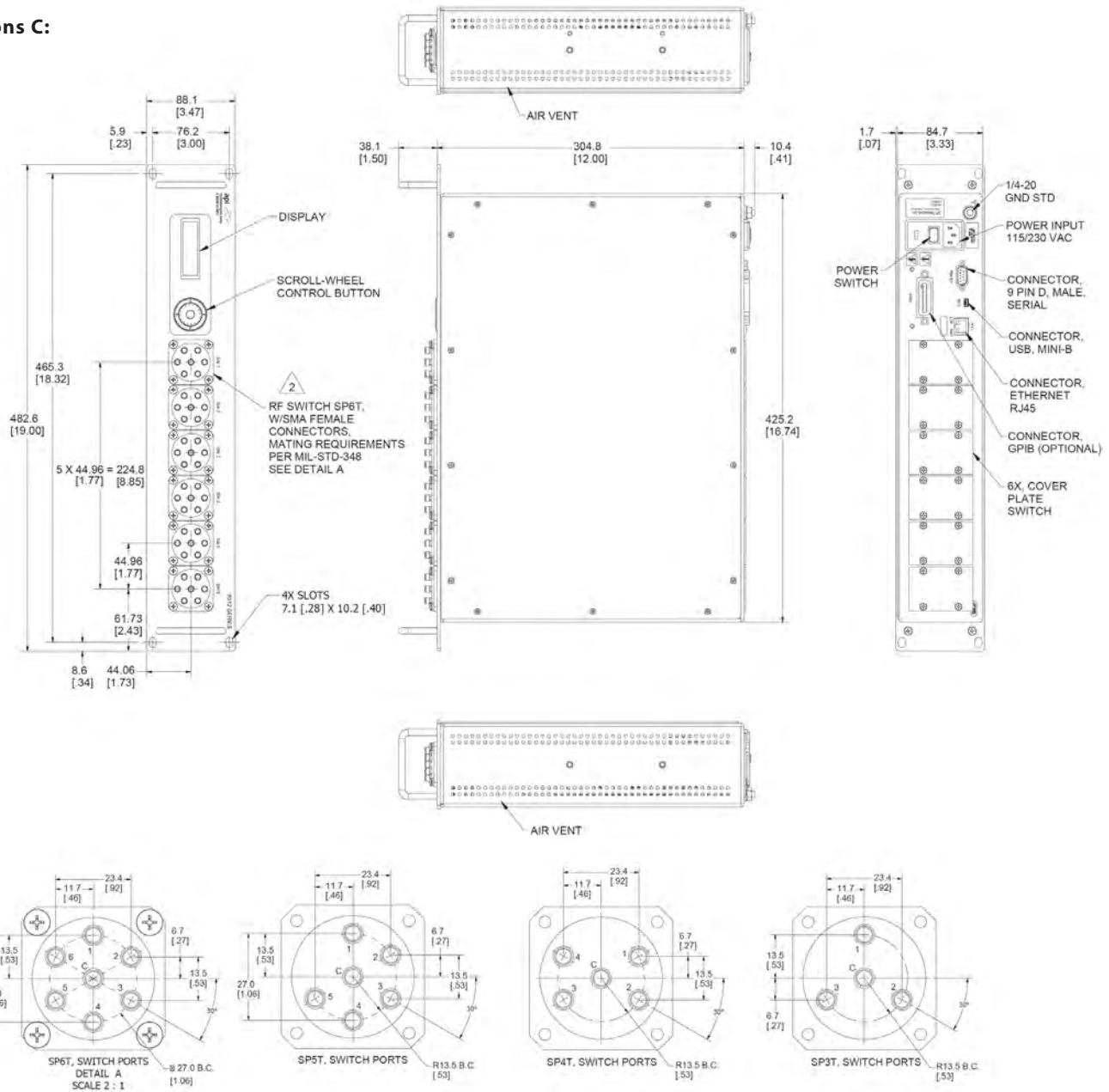

### Notes:

1. All dimensions are given in mm (inches).
2. RF Switches and switch plates as required and determined by configuration. Six switch unit configuration shown.





## Model 8390 & 8390-1 Amplifier / Switch Units

Weinschel Models 8390 and 8390-1, Amplifier / Switch Unit is comprised of an array of eight input switches (S1-S8), a relay-based step attenuator that provides 0-31 dB of attenuation in 1 dB steps and an output RF amplifier. Switch, S8 is terminated with a 50 Ω termination at port 2. Each input/output port contains a masking pad. The unit includes a front-panel interface for status and control, and supports programming via a serial RS232 port and/or 10/100 BaseT Ethernet port.

Choice of Frequency Ranges:

- Choice of Frequency Ranges
  - Model 8390: 3.4 to 4.2 GHz
  - Model 8390-1 0.95 to 13 GHz
- Can be rack mounted into any rack or cabinet designed per EIA of MIL-STD-189

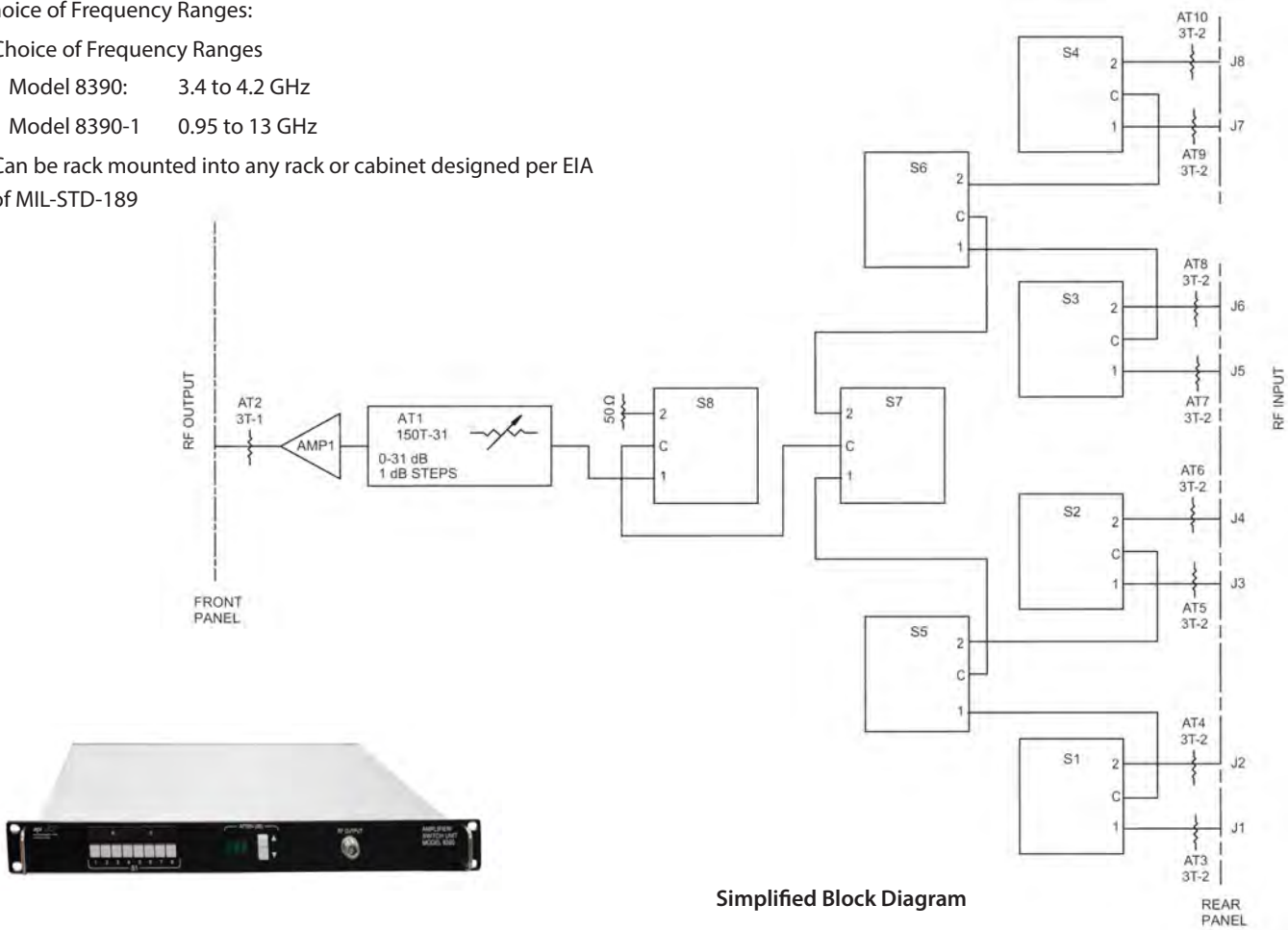

Simplified Block Diagram

**EXPORT CONTROL:** This product is controlled for export under the International Traffic in Arms Regulations (ITAR). A license from the U.S. Department of State is required prior to the export of this product from the United States.

**EXPORT WARNING:** Military and space products are controlled for export under the International Traffic in Arms Regulations (ITAR) and may not be sold or proposed or offered for sale to certain countries. (See ITAR 126.1 for complete information.)



## Physical Dimensions

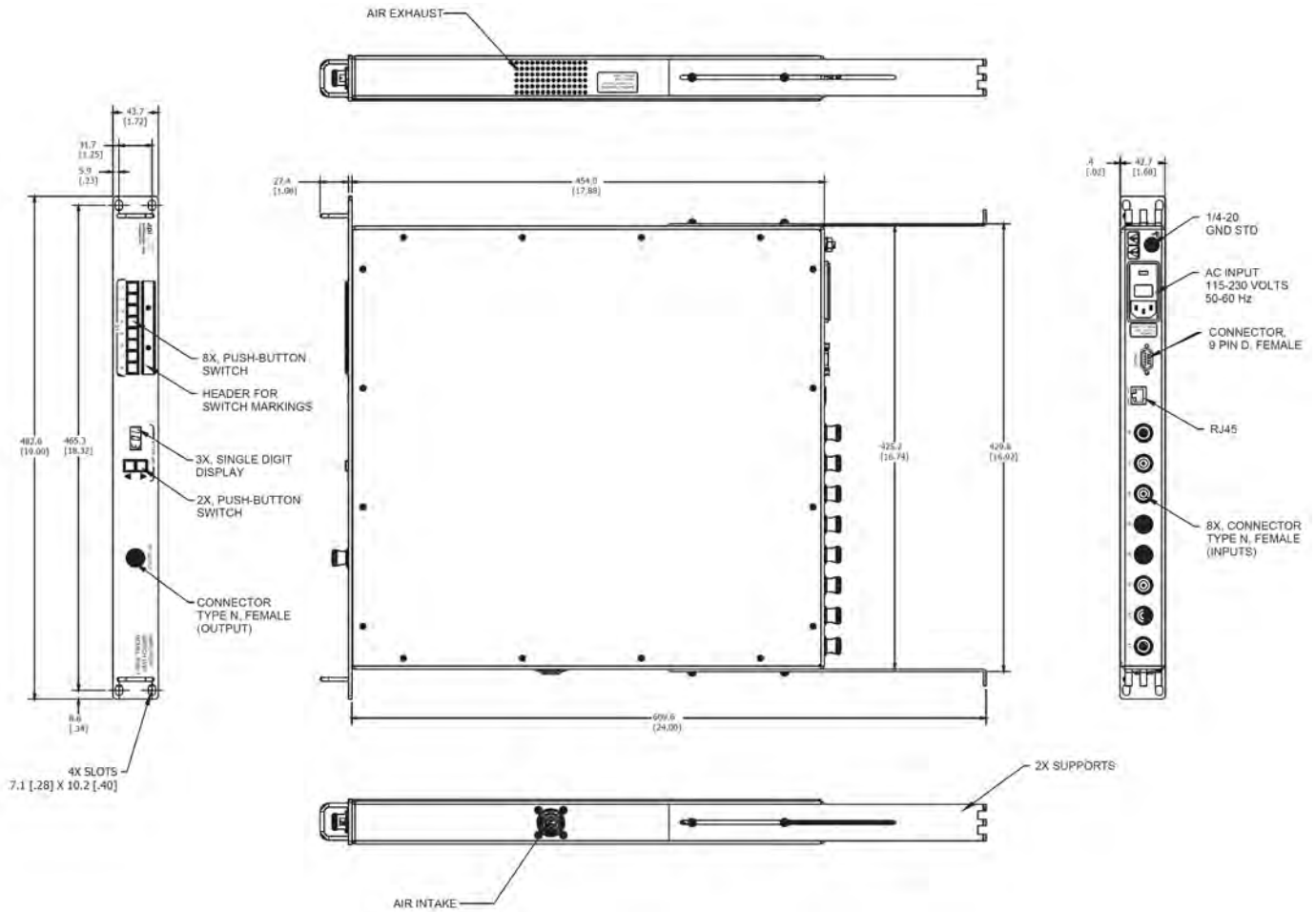

**NOTE:** All dimensions are given in mm (inches) and are maximum, unless otherwise specified.





## Precision Step Attenuator Unit, Model 3057

Model 3057 Series Precision Step Attenuators are designed for use in automatic test equipment and OEM systems operating in the DC to 1.5 GHz frequency range. This design contains three APITech Weinschel Manual Step Attenuators connected in series to provide 0 to 50 dB of attenuation with 0.1, 1.0 and 10.0 dB of resolution.

- Wide Dynamic Range - Up to 50 dB of attenuation with 0.1 dB resolution.
- Excellent Repeatability.
- Highly Accurate Detent Stepping
- Compact 2 RU, 19" Rack Mount Configuration.



### Specifications

- Nominal Impedance:** 50  $\Omega$
- Frequency Range:** dc to 1.5 GHz
- Attenuation Range:** 0 to 50 dB
- Resolution:** 0.1 dB, 1.0 dB, 10.0 dB
- Attenuation Accuracy:** 0 - 0.9 dB:  $\pm 0.1$  dB  
1.0 - 50dB:  $\pm 0.2$  dB
- Insertion Loss:** 1.5 dB maximum
- VSWR:** 1.3:1 maximum
- Repeatability:** 0.02 dB
- Maximum Power Rating:** 1 watt
- Temperature Range:** Operating: 0°C to +54°C  
Nonoperating: -54°C to +54°C

## Low Passive Intermodulation Fixed Attenuators & Terminations

Weinschel announces a New line of Low Passive Intermodulation (PIM) coaxial fixed attenuators and terminations. These designs offer models with power handling up to 175 watts with PIM levels, 3rd Order IM Magnitude (IM3) down to -120 dBc to -150 dBc.

- Low PIM design
- Quality connectors with special high temperature support beads
- Rugged connectors, free solder joints



Models  
298/1492



Models  
254/1479



Models  
264

Fixed Attenuators					
Model Number	Connector Type	Frequency Range (GHz)	Average Power (W)	Standard Attenuation Values (dB)	SWR (Max.)
264-XX-XX	SMK (2.92mm)/ N	DC-8.5	50	10, 20, 30, 40	1.20-1.30*
298-XX-XX	SMK (2.92mm)/ N	DC-6.0	100	10, 20, 30, 40	1.10-1.15*
254-XX-XX	SMK (2.92mm)/ N	DC-6.5	175	10, 20, 30, 40	1.10-1.20*



Terminations & Loads				
Model Number	Connector Type	Frequency Range (GHz)	Average Power (W)	SWR (Max.)
1491-X	SMK (2.92mm) / N	DC-8.5	50	1.20-1.30*
1479-X	SMK (2.92mm) / N	DC-6.5	175	1.10-1.20*



Models  
1491

**Notes:**

- \* = *Varies with Frequency*
- Connector options:**
  - (SMK female)
  - (SMK male)
  - (N female)
  - (N male)

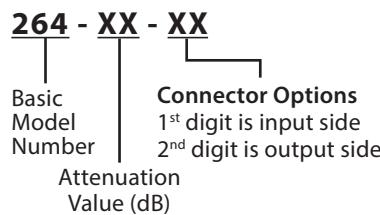

## Conduction Cooled (Flat-Pack) Fixed Attenuators & Terminations

APITech Weinschel line of conduction cooled flat-pack coaxial fixed attenuators and terminations is expanding to include new models covering the DC to 10 GHz frequency range. These products offer several models with power handling up to 550 watts.

- Precision Connectors with high temperature support beads
- Designed to meet environmental requirements of MIL-DTL-3933
- 10 Kilowatts peak, Conduction Cooled
- Low Intermodulation Distortion Option available on select models
- Wireless Applications - Optimized for use in the communications bands



Fixed Attenuators					
Model Number	Connector Type	Frequency Range (GHz)	Average Power (W)	Standard Attenuation Values (dB)	SWR <sup>1</sup> (Max.)
253-XX-XX**	SMK (2.92mm) / N	DC-6.0	550	10, 20, 30, 40	1.10-1.20*
257-XX-XX**	SMK (2.92mm) / N	DC-6.0	250	10, 20, 30, 40	1.10
258-XX-XX**	SMK (2.92mm) / N	DC-6.0	400	10, 20, 30, 40	1.10-1.25*
268-XX-XX**	SMK (2.92mm) / N	DC-6.0	100	6, 10, 20, 30, 40	1.10-1.15*
275-XX-XX	SMK (2.92mm)	DC-40.0	5	3, 6, 10, 20, 30	1.25-1.45*
284-XX-XX**	SMK (2.92mm) / N	DC-10.0	50	3, 6, 10, 20, 30, 40	1.15-1.30*





**Notes:**

1. \* = *Varies with Frequency*
2. \*\* = *Low Intermodulation available*
3. **Connector options:**
  - 1 (SMK female)
  - 2 (SMK male)
  - 3 (N female)
  - 4 (N male)

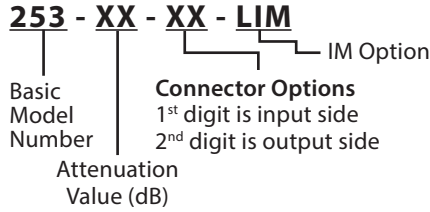

Termination & Loads					
Model Number	Connector Type	Frequency Range (GHz)	Average Power (W)	Peak Power	SWR <sup>1</sup> (Max.)
1470-X**	SMK (2.92mm) / N	DC-6.0	100	10	1.20
1471-X**	SMK (2.92mm) / N	DC-6.0	250	10	1.20
1472-X**	SMK (2.92mm) / N	DC-6.0	400	10	1.20
1473-X**	SMK (2.92mm) / N	DC-6.0	550	10	1.20
1474-X**	SMK (2.92mm)	DC-40.0	5	0.2	1.25-1.45*



**Notes:**

1. \* = *VARIABLES WITH FREQUENCY.*
2. \*\* = *Low Intermodulation available. Add -LIM to Model number*
3. -X = *Connector Option: -1 (SMK female), -2 (SMK male), -3 (N female), -4 (N male)*

## High Reliability Attenuators (DC to 18 / 40 GHz)

Since 1952, Weinschel has supplied high quality precision coaxial attenuators and terminations to test and calibration labs throughout the world. These products offer rugged construction, frequency ranges up to 40 GHz, many standard dB values and power handling to 1,500 Watts.

Weinschel has released the Model 32K, DC to 40 GHz, 2 Watt High Reliability Fixed Coaxial Attenuator designed specifically for space applications. The Model 32K is available with SMK connectors in dB values of 3, 6, 10, 20 and 30. Other features include 1.25-1.45 maximum SWR, + 1.00-1.50 dB deviation, quality connectors, and an operating temperature range of -55 °C to +100 °C.

Also being introduced is a line of hi-reliability fixed attenuators (Models 272-274, 276) specifically designed as commercial alternative to MIL-DTL-3933 CLASS IIWI/IVE, N/S (N=Non-Screened, S=Screened) attenuators. These units are designed to meet the MIL-DTL-3933 requirements.



Model 273



Model 32K



Model 274



Model 272



Model 276



Model Number	Connector Type	Frequency Range (GHz)	Average Power (W)	Standard Attenuation Values (dB)	SWR <sup>1</sup> (Max.)
32K	SMK (f-m)	DC-40.0	0.50	3, 6, 10, 20, 30	1.25-1.45
272-XX-N/S	N (f-m)	DC-18.0	0.5	1- 10, 20, 30, 40	1.12-1.20
273-XX-N/S	SMA (f-m)	DC-18.0	0.5	0-10 in 0.5 increments, 11- 20 in 1 increments, 25 - 40 in 5 increments	1.10-1.35
274-XX-N/S	SMA (f-m)	DC-18.0	0.5	0-20 in 0.5 increments, 30, 40	1.15-1.35
276-XX-N/S	N (f-m)	DC-18.0	1.0	3, 6, 10, 20, 30	1.15-1.40

**Notes:**

1. *Varies with frequency.*
2. *Custom dB values available.*
3. *XX = Standard dB Value, f = female, m = Male*

**Features**

- Screened and Non-screened models available.
- Choice of attenuation values.
- Frequency Ranges from DC to 18 GHz.
- Power capability from 2 to 25 watts.
- Test Data supplied at additional cost as follows:  
**Non-screened (N):** Swept data plots of Attenuation and SWR across the frequency band.  
**Screened (S):** Swept data plots of Attenuation and SWR across the frequency band. Film, Standard data package includes lot record performance showing pass/fail quantities for all tests and test reports as applicable.

**Screening**

Units are screened as follows:

**"N" versions:**

- SWR
- Attenuation Peak Power

**"S" versions:**

- Thermal Shock
- Monitored Thermal Cycle (MTC)
- Attenuation w/Parts Assembly Verification (PAV)
- Conditioning
- Peak Power Attenuation SWR
- Radiographics

## Medium & High Power Attenuators, Terminations & Mismatches (DC to 6 / 18 GHz)

APItech Weinschel continues to expand its medium and high power fixed coaxial attenuator and termination offering with the additions of new models with:

- The Model 251 is a convection cooled, 200 W Bi-directional design that operates over the DC to 6 GHz frequency range. Available in standard dB values of 10, 20, 30 and 40. Standard Type N or SMK (2.92mm) connectors.
- Designs DC to 40 GHz, 10 W (Model 279 / 1477) and 20 W (Model 89 / 1478) with choice of SMK (2.92mm) male / female connectors.
- New body style 50 W (Model 90 / 1468) and 100 W (Model 260 / 1467) designs that operate over the DC to 18 GHz frequency range with Type N or 3.5mm connectors and are available in 50 W or 100 W configurations. Standard dB values: 3, 6, 10, 20, 30.
- APItech Weinschel introduces a new line of Medium and High Power Mismatches that operate over the DC to 6 GHz frequency range. This Model offers mismatch SWR values of 2 to 6.5 in 0.5 increments.







## Who We Are

### Value-added Integration from Components to Subsystem Solutions

APItech provides rugged, reliable, and efficient subsystems, assemblies, and components for use in the most mission critical defense and military applications, supporting government programs throughout the world. With diverse program experience and preferred supplier status with some of the industry's top premier contractors, our precision-engineered MIL-grade products are ideal for applications where uncompromised reliability and uninterrupted performance is required. APItech is the Electromagnetic Spectrum Innovator at Tier 2.5-4 in the supply chain.

SYSTEMS INTEGRATION  
SYSTEM PRIME



F-35

MISSION/INTEGRATED SYSTEMS  
TIER 1



Radar or Communications

INTEGRATED SUBSYSTEMS & BOXES  
TIER 2



Radio or Interface Assembly

MODULES  
TIER 3



IMAS

COMPONENTS  
TIER 4



Passive COAX

## The Electromagnetic Spectrum Innovator

APItech is an innovative designer and manufacturer of high performance systems, subsystems, assemblies and components for technically demanding RF, microwave, millimeterwave, electromagnetic, power, and security applications. A high reliability technology pioneer with over 70 years of heritage, APItech's products are used by global defense, industrial, and commercial customers in applications spanning radar, electronic warfare, unmanned systems, missile defense, harsh environments, space, communications, medical, test and instrumentation, and more.



[www.weinschel.apitech.com](http://www.weinschel.apitech.com) | 301.846.9222

CONTACT US