



# Attenuators for Cryogenic Applications

## Table of Contents

- 2 Cryo Attenuators for Quantum Computing
- 3 Powerfilm Chip Attenuators for Cryogenic Applications
- 4 Model 9102 (SMA, 18 GHz)
- 5 Model 9104 (2.92mm, 40 GHz)
- 6 Model 3175M (SMA-Male 18GHz Termination)
- 7 Model CCAAW (Chip Attenuator, DC-18 GHz)
- 8 Model CCAAF (Chip Attenuator, DC-8 GHz)

Learn about how Spectrum Control's cryo attenuators, tested to 4mK, support quantum computing installations and other cryogenic applications.

You'll find Spectrum's attenuators in satellites, radar systems, mobile testing equipment, helping service providers deliver coverage, and performing under some of the harshest conditions.

## Cryo Attenuators for Quantum Computing

*Helping solve the problems of thermal noise in cryogenic chambers*

Spectrum Control is working to customize and optimize fixed attenuators for use in cryogenic cooling systems to support quantum computing. Quantum computing will revolutionize our understanding of the world by analyzing datasets that today's most powerful supercomputers can't handle. Instead of bits, quantum computers use quantum bits (qubits) which can only be detected at extremely small energy levels -- and at temperatures close to absolute zero. This requires cryogenic refrigeration systems with multiple stages of cooling and numerous RF cables of significant length, all of which introduces thermal noise, harming the integrity of the qubit. Spectrum Control's coaxial cryo-attenuators, mounted at different temperature stages of the cryo chamber, help solve this problem.

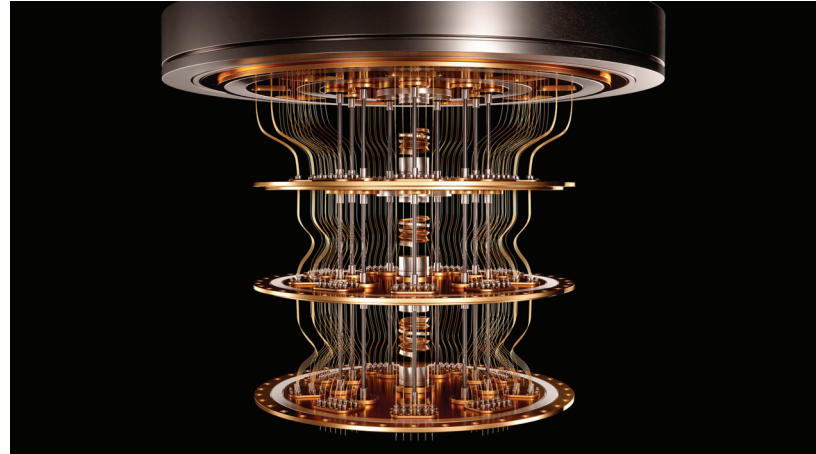

*Quantum Computer*

### Ensuring Integrity of the Qubit

To be 'read' a qubit must be isolated from even the most minute amount of interference. The cryogenic chambers needed for this function can reach temperatures down to 4mK (milli-Kelvin). This can require thousands of coaxial attenuators able to function in this environment. Spectrum Control's attenuators, designed for mK operation to avoid self-heating, are reliable at temperatures these cryo installations require.

#### ***Spectrum Control cryo attenuators tested to 4mK***

Eliminating thermal noise in a quantum computing installation demands a high degree of innovation and reliability. Spectrum Control's experience delivering custom components for use in harsh environments and high reliability requirements, like space, is the foundation supporting our work in cryogenic technology.

Using our in-house resistor fabrication processes and materials, Spectrum Control is able to optimize the resistor material, substrate and fabrication processes as well as the mechanical design needed to offer a "thermally quiet" attenuator solution at mK temperatures.

### Innovation & Customization

For over 60 years, Spectrum Control has been the world's leading innovator and supplier of passive coaxial and RF components. Features of the attenuators used in these cryo environments include:

- Gold plated beryllium copper conductors
- DC - 40 GHz (2.92mm connector)
- DC - 18 GHz (SMA and SMPM connectors)
- Available dB values of 0, 3, 6, 10, 20 dB
- Proprietary thin film resistor material
- Operating temperature down to 20mK



*DC-40 GHz cryo attenuator with  
2.92mm connector (Model 9104)*

## Powerfilm Chip Attenuators for Cryogenic Applications

*Proprietary thin-film technology maintains resistance down to near absolute zero*

Spectrum Control's line of Powerfilm chip attenuators and resistors are used in aerospace, satellite, and other extreme environments, so it's no surprise our parts are a go-to choice for cryogenic applications such as quantum computing. Powerfilm cryogenic chip attenuators retain their electrical characteristics down to near absolute zero (0K) temperatures where quantum effects are dominant.

### Performance Maintained at Cryo Temperatures

Eliminating thermal noise in a quantum computing installation, or supporting any cryo application, demands a high degree of performance and reliability. Most common thick-film resistors become insulators and turn attenuators into opens. Common thin-film resistors become super-conductive and turn attenuators into shorts. Powerfilm's cryogenic thin-film technology maintains its resistance to less than 1K.

*The leader in high power attenuators, resistors and terminations, with the proven ability to customize designs and deliver for any quantity.*

Spectrum Control's expertise in delivering custom components for use in harsh environments with high reliability requirements, like space, is the foundation supporting our work in cryogenic technology. Design, testing, manufacturing and application support are performed in-house.



### Testing, Customization & Optimization

The Powerfilm team can analyze each customer's application requirements and determine opportunities to deliver optimized performance for power, frequency, size, finish, attenuator accuracy, volumes, mounting, and how the chip should be placed; all to deliver optimum results. For our standard Cryo Low Temp chip attenuator, features include:

#### Cryo Low Temp Chip Attenuators:

- Frequency range DC - 18 GHz
- 0 - 20 dB
- 50 Ohms
- Alumina substrate
- Gold terminals; gold, silver, tin-lead and lead-free solder finishes available
- Mounted circuit side up or down
- 4 mK to +150 Celsius
- MIL-PRF-55342, MIL-PRF-55182, MIL-DTL-8833 testing available

Powerfilm CCAA cryogenic chip attenuators have gold terminals suitable for both solderable or wire-bondable applications.

# Attenuator, SMA

Model 9102-CRYO

## Features

- Stable Attenuation over temperature
- Low thermal noise characteristics
- Minimal self heating, achieves temperature faster
- Optimized non-magnetic material selection.

## Technical Specifications

Parameter	Value
Frequency Range	DC to 18 GHz
Standard dB Values	0, 3, 6, 10 & 20dB
Attenuation Accuracy (dB)	
0dB	+0/-0.4dB
3 & 6dB	±0.3dB
10 & 20dB	±0.5dB
VSWR	
DC – 4 GHz	1.15:1 Max.
4 – 12.4 GHz	1.25:1 Max.
12.4 – 18 GHz (1-20dB)	1.35:1 Max.
12.4 – 18 GHz (0dB only)	1.45:1 Max.
Input Power	2 Watts Avg. @ 25°C
Impedance	50 Ohms
Operating Temp. Range	4°mK to +125°C

## How to Order

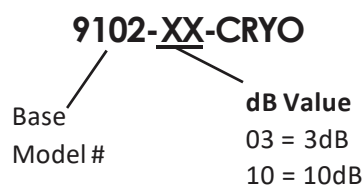

Design Specifications are subject to change without notice.

**Frequency Range: DC to 18.0 GHz**  
**Power: 2Watts**



## Mechanical

Feature	Material
SMA Connectors <i>Mates with MIL-STD-348</i>	White Bronze Plated Brass
Conductors	Gold Plated Beryllium Copper
Substrate	Beryllium Oxide
Resistor Material	Proprietary Thin Film

## Physical Dimensions

Model Number: 9102-03-CRYO shown

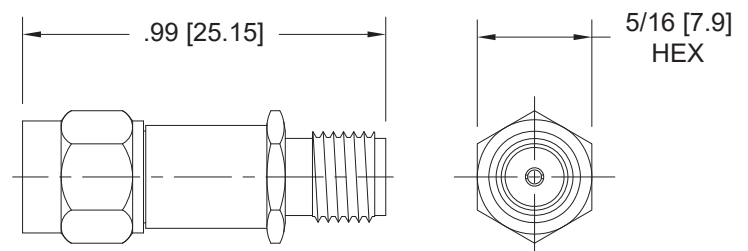

Note: Dimensions in Brackets [ ] are expressed in millimeters and are for reference only.

## Order Examples

Model Number: 9102-03-CRYO

DC-18 GHz, 3dB, SMA Male/Fem

# Attenuator, 2.92mm

Model 9104-CRYO

## Features

- Stable Attenuation over temperature
- Low thermal noise characteristics
- Minimal self heating, achieves temperature faster.
- Optimized non-magnetic material selection.

## Technical Specifications

Parameter	Value	
Frequency Range	DC to 40 GHz	
Standard dB Values	0, 3, 6, 10, 20 & 30dB	
Attenuation Accuracy (dB)	DC – 26.5 GHz	26.5 – 40 GHz
	0, 3 & 6dB	±0.5dB ±0.8dB
	10 & 20dB	±0.6dB ±1.0dB
	30dB	±0.8dB ±1.0dB
VSWR	DC – 18 GHz	1.30:1 Max.
	18 – 40 GHz	1.40:1 Max.
Input Power	2 Watts Avg. @ 25°C	
Impedance	50 Ohms	
Operating Temp. Range	4°mK to +125°C	

**Frequency Range: DC to 40.0 GHz**  
**Power: 2Watts**



## Mechanical

Feature	Material
2.92mm Connectors	White Bronze Plated Brass
<i>Mates both mechanically &amp; electrically with all SMA, K* &amp; 3.5mm series connectors.</i>	
Conductors	Gold Plated Beryllium Copper
Resistor Material	Proprietary Thin Film

\*K is a trademark of Anritsu/Wiltron Corp.

## Physical Dimensions

Model Number: 9104-03-CRYO shown

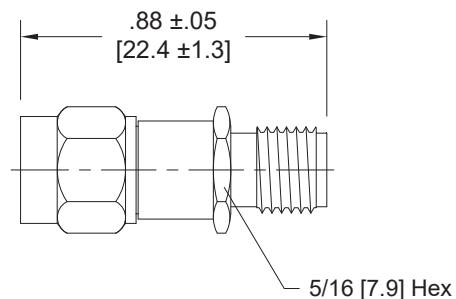

*Note: Dimensions in Brackets [ ] are expressed in millimeters and are for reference only.*

## Order Examples

Model Number: 9104-03-CRYO

DC-40 GHz, 3dB, 2.92mm Male/Fem

## How to Order

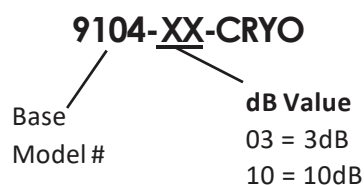

*Design Specifications are subject to change without notice.*

rev A

## Termination, SMA

Model 3175M-CRYO

### Features

- Stable Attenuation over temperature
- Low thermal noise characteristics
- Minimal self heating, achieves temperature faster
- Optimized non-magnetic material selection

**Frequency Range: DC to 18.0 GHz**  
**Power: 2 Watts**



### Technical Specifications

Parameter	Value
Frequency Range	DC to 18 GHz
VSWR	1.25:1 Max.
Input Power	2 Watts Avg. @ 25°C
Impedance	50 Ohms
Operating Temp. Range	-4°mK to +125°C

### Mechanical

Feature	Material
SMA Connectors <i>Mates with MIL-STD-348</i>	White Bronze Plated Brass
Conductors	Gold Plated Beryllium Copper
Substrate	Beryllium Oxide

### Physical Dimensions

Model Number: 3175M-CRYO shown

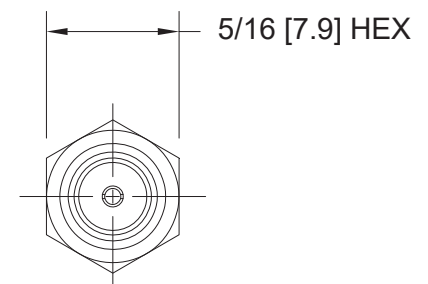
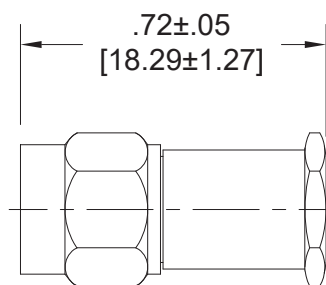

### How to Order

**3175M - CRYO**

Base  
Model #

*Dimensions in brackets [ ] are expressed in Millimeters and are for reference only.  
Design Specifications are subject to change without notice.*

REV B

# Attenuator Chip, Cryo Low Temp

## DC - 18 GHz CCAAW

Models: CCAAW-X, CCAAW-TX, CCAAW-HX, CCAAW-GX

### Specifications

#### Electrical

Frequency Range	DC - 18 GHz
Normal Impedance	50 Ohms
Standard dB Values	0 thru 20 dB
Attenuation Accuracy (dB)	

dB Value	DC-4 GHz	4-8 GHz	8-12.4 GHz	12.4-18 GHz
0	+0.5/-0	+0.5/-0	+0.5/-0	+0.5/-0
1-3	±0.5	±0.5	±0.5	±0.5
4-6	±0.5	±0.5	±0.5	±0.75
7-10	±0.5	±0.5	±0.75	±1.00
11-15	±0.75	+0.5/-3	+0.5/-4	
16-20	±1.00	+0.5/-4		

#### VSWR

DC - 4 GHz	1.25:1 Max.
4 - 8 GHz	1.35:1 Max.
8 - 18 GHz	1.50:1 Max.

#### Rated Power (Mounted Circuit side up or down)

dB Value	Watts	dB Value	Watts	dB Value	Watts
0	4.0	3	2.0	12	0.75
1	4.0	6	1.0	15	0.75
2	2.0	10	1.0	20	0.75

Operating Temp. Range    4°mK to +150°C

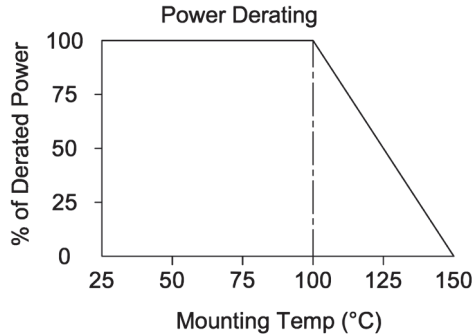

#### Mechanical

**Substrate:** Alumina  
**Wirebondable Terminals:** Gold

See "How to Order" for Tinning & other options

#### How to Order

**Model Number:** CCAAW - Y X

**Terminal Options** \_\_\_\_\_ dB Value  
 = Silver over Nickel  
 T = Tin Lead Solder  
 H = Lead Free Solder  
 G = Gold Plated

#### Model Number: CCAAW-G3

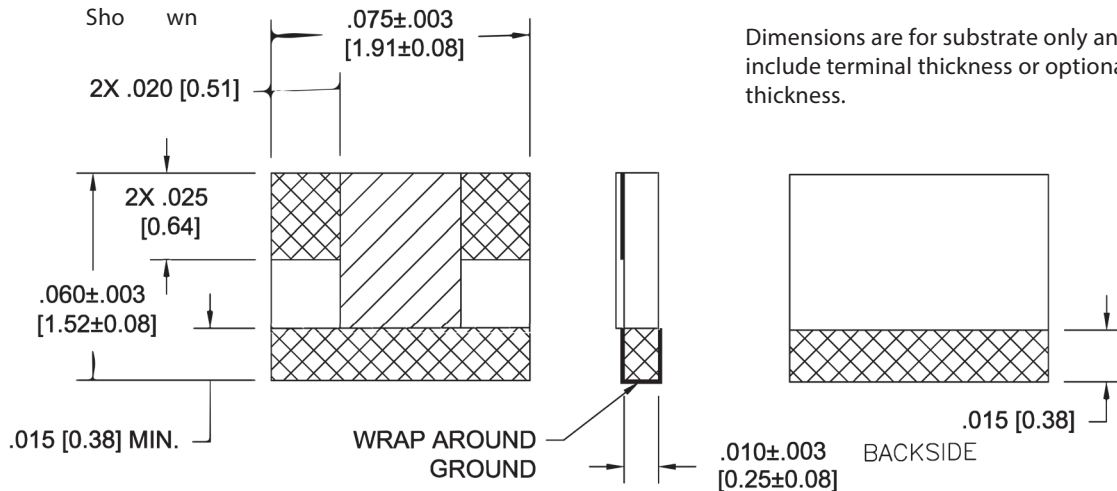

Tolerance .XXX = ±.010

Dimensions are for substrate only and do not include terminal thickness or optional tinning thickness.

*Note: Dimensions in Brackets are Expressed in Millimeters and are for Reference Only.  
 Design specifications are subject to change without notice.*

# Attenuator Chip, Cryo Low Temp

**DC - 8 GHz  
CCAAF**

Models: CCAAF-X, CCAAF-TX, CCAAF-HX, CCAAF-GX

## Specifications

### Electrical:

<b>Frequency Range</b>	DC - 8 GHz
<b>Norminal Impedance</b>	50 Ohms
<b>Standard dB Values</b>	0 thru 20 dB
<b>Attenuation Accuracy (dB)</b>	

dB Value	DC-4 GHz	4-8 GHz
0	+0.5/-0	+0.5/-0
1-10	±0.5	±0.5
11-15	±0.75	+0.5/-3
16-20	±1.0	+0.5/-4

### VSWR

<b>DC - 4 GHz</b>	1.25:1 Max.
<b>4 - 8 GHz</b>	1.35:1 Max.

### Rated Power (Mounted Circuit side up or down)

dB Value	Watts	dB Value	Watts	dB Value	Watts
0	5.0	3	2.0	12	0.75
1	5.0	6	1.0	15	0.75
2	2.0	10	1.0	20	0.75

**Operating Temp. Range** 4°mK to +150°C

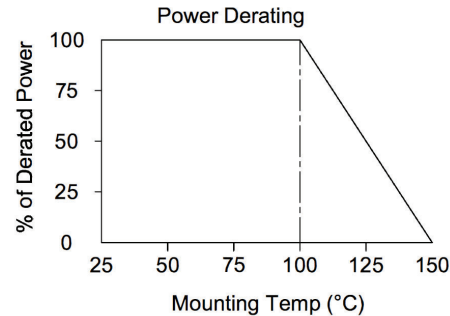

### Mechanical

**Substrate** Alumina  
**Terminals** Tin Lead Solder (Standard)

See "How to Order" for Tinning & other options

### How to Order

**Model Number: CCAAF - Y X**

**Terminal Options** \_\_\_\_\_ dB Value  
 = Silver over Nickel  
 T = Tin Lead Solder  
 H = Lead Free Solder  
 G = Gold Plated

### Model Number: CCAAF-T3

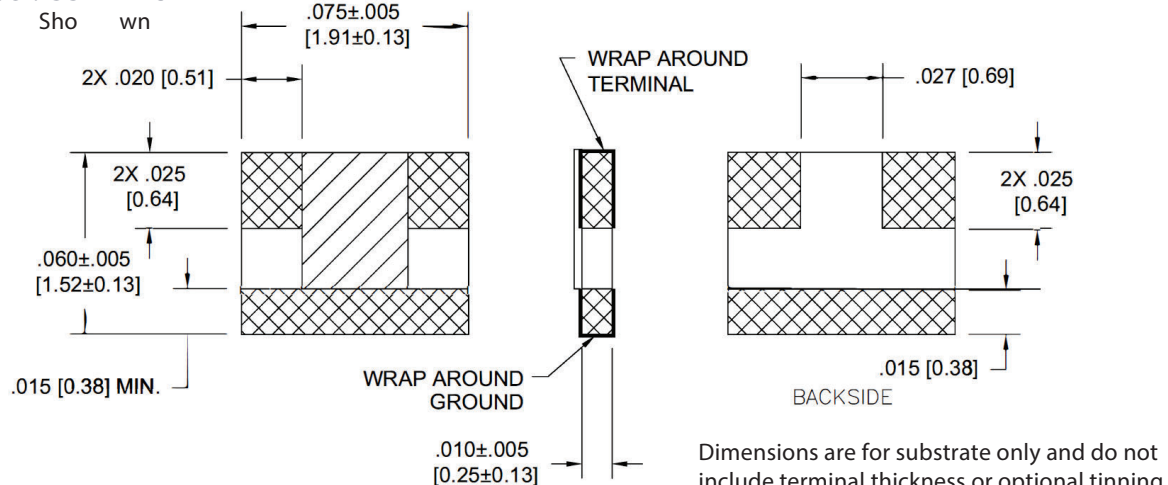

*Note: Dimensions in Brackets are Expressed in Millimeters and are for Reference Only.  
 Design specifications are subject to change without notice.*