

NOTES:

- 1. HOUSING & SEAL COVER ALUMINUM, COVER IS LASER WELDED TO FORM A HERMITIC SEAL.
HOUSING: IS NICKEL PLATED PER AMS-C-26074 CLASS 3, GRADE B,
WELD COVER: CHEMICAL FILM MIL-DTL-5541, TYPE II CLASS 3

REVISIONS				
ECN	REV.	DESCRIPTION	CHNG/DATE	APPVD/DATE
XXXXX	-	RELEASE	2016/08/30	

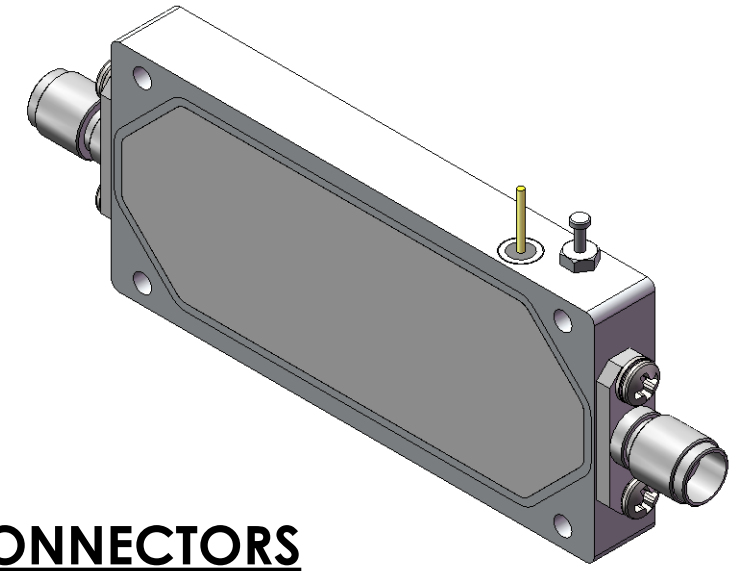
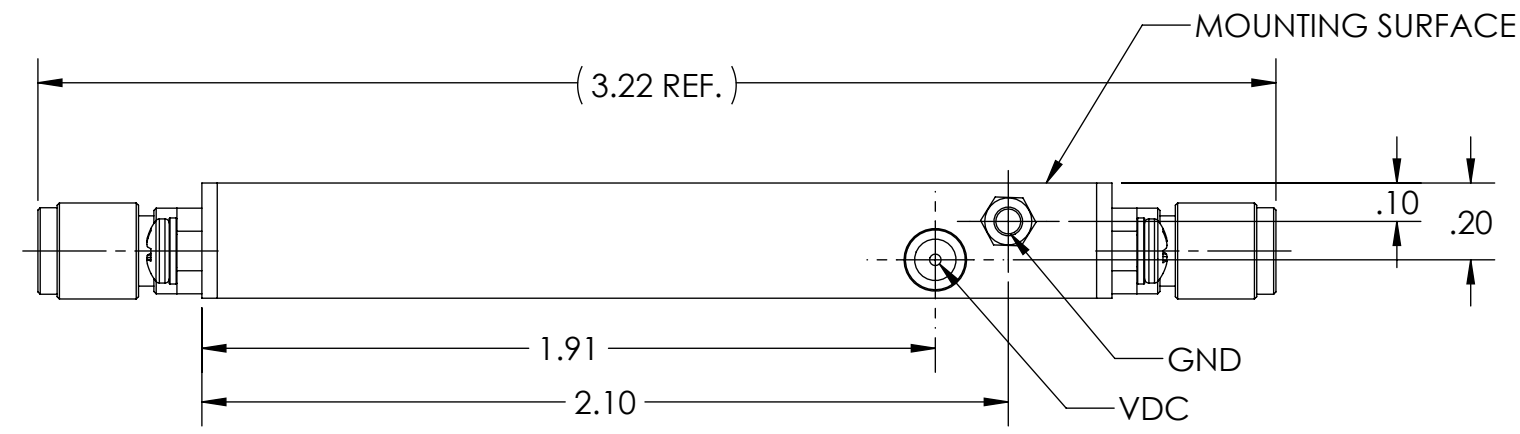

SMA CONNECTORS REMOVED

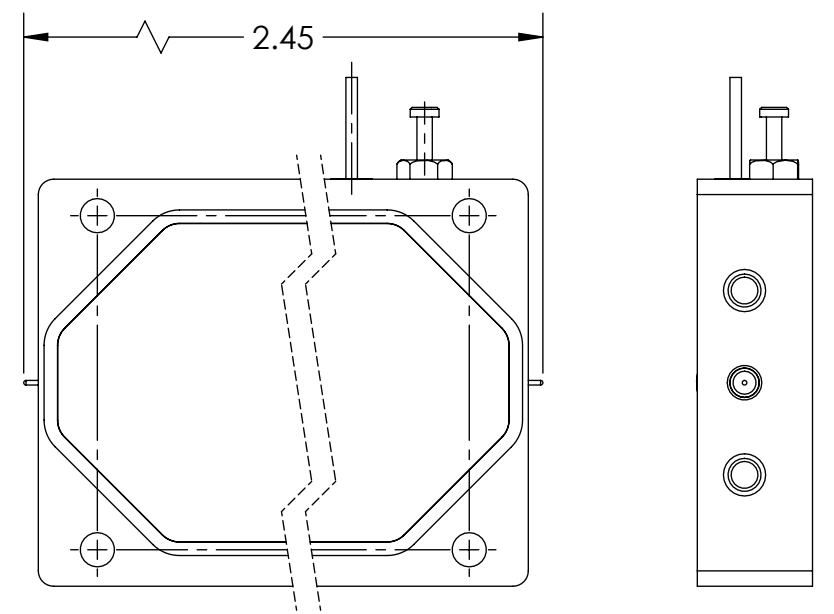

SEE SEPARATE PARTS LIST IN ELECTRONIC STORAGE

B

B

A

A

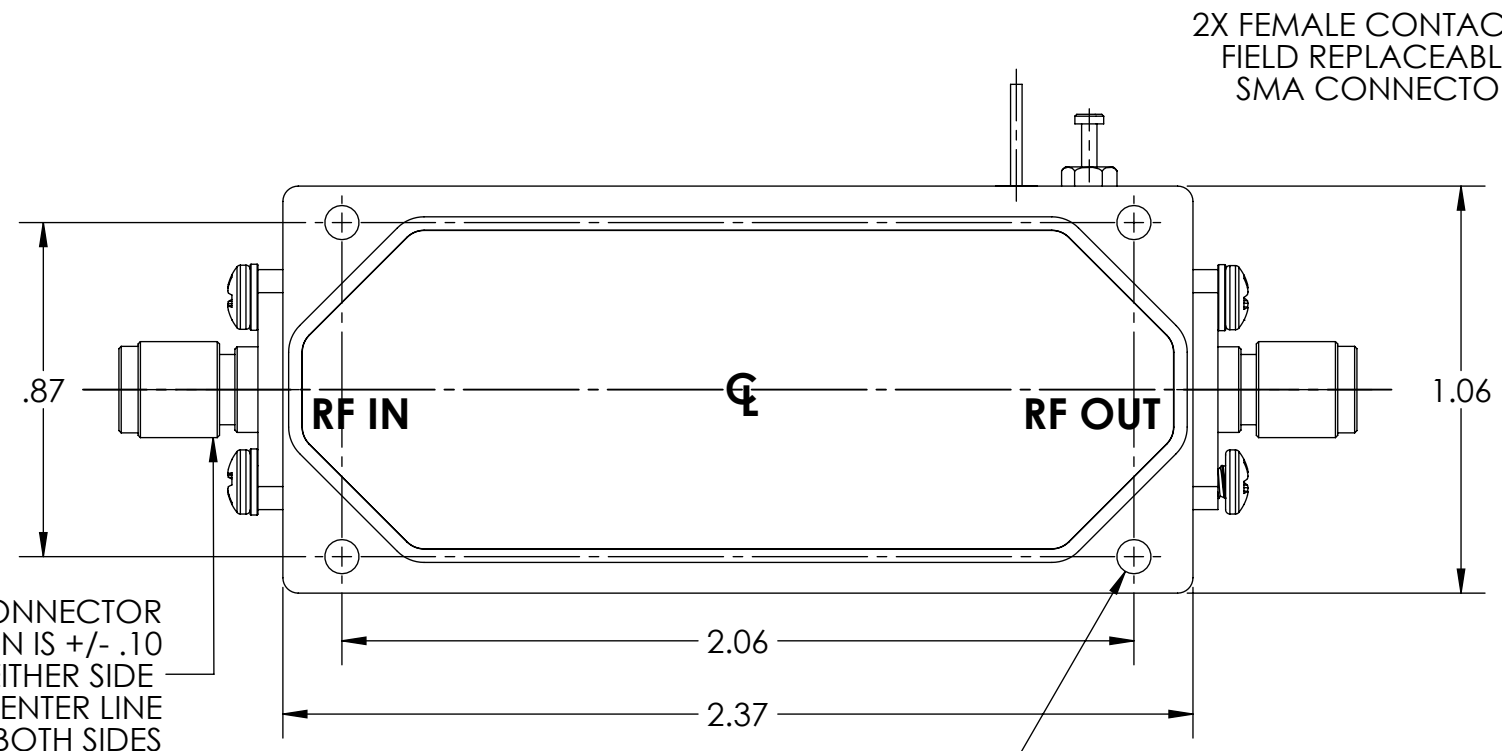

4X Ø .09 THRU ALL

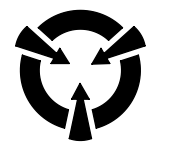

CAUTION

THIS ASSEMBLY CONTAINS PARTS SENSITIVE TO DAMAGE BY ELECTROSTATIC DISCHARGE (ESD). USE ESD PRECAUTIONARY PROCEDURES WHEN TOUCHING, REMOVING OR INSERTING

API TECHNOLOGIES CORP. PROPRIETARY INFORMATION
THIS DOCUMENT IS THE SOLE PROPERTY OF API TECHNOLOGIES CORP. THE RELEASE OF DATA CONTAINED IN THIS DOCUMENT AND THE REPRODUCTION OF THIS DOCUMENT, IN WHOLE OR IN PART, WITHOUT THE WRITTEN PERMISSION OF API TECHNOLOGIES CORP. ARE PROHIBITED.

UNLESS OTHERWISE SPECIFIED	3rd ANGLE PROJECTION	
* INTERPRET DRAWING IAW ASME Y14.100-2004	ANSI	
* DIMENSIONING AND TOLERANCING IAW ASME Y14.5-1994	DRAWN	DATE
* PARENTHEetical INFORMATION FOR REFERENCE ONLY	WAR	2014-01-22
* DIMENSIONAL LIMITS APPLY BEFORE PROCESSES	CHECKED	
* DIMENSIONS ARE IN INCHES	ENGRG	
* TOLERANCES ARE: ANGLES ±1.0°	HP	2014-01-22
63	MFG	
2 PLACE DECIMAL ±.02	QA	
3 PLACE DECIMAL ±.005		
* REMOVE ALL BURRS AND SHARP EDGES .010 RAD MAX.		
* CONCENTRICITY MACHINED DIA: .002 FIM		
* MACHINED TOOL MISMATCH: .002 MAX.		
DO NOT SCALE DRAWING		

api technologies corp.		PHILADELPHIA OPERATIONS 2707 BLACK LAKE PLACE, PHILADELPHIA PA. 19154 (USA)	
TITLE			
OUTLINE, HF3			
SIZE	CAGE CODE	DWG NO.	REV
B	60979	088-00421	-
SCALE:		SHEET	
2.5:1		1	OF 1