

# Waved Metal Gaskets

Proper mounting of an EMI filter is critical to achieving optimum filtering performance. For applications requiring very high attenuation, it is necessary to fill the gaps at the mounting surface-to-connector interface. The length of any gap must be short, relative to the wavelength of the signal to be attenuated. Spectrum Control supplies a line of "waved" gaskets. This design ensures the maximum "gap length" will not exceed the wave pitch, .200" (5.08mm), even on the surfaces with poor flatness. This ensures maximum filter performance to 1 GHz and beyond.



**Waved Metal**  
Grounding/Shielding Gasket (shown in free state)

## Specifications

- Material* . . . . . Beryllium Copper, CA 172  
(per QQ-C-533)
- Finish* . . . . . STD: Electro tin plate, 100 micro  
inches (per MIL-T-10727)
- Material Thickness* . . . . . .005" (.13mm) compressed
- Wave Height* . . . . . .030" +.020/- .015  
(.76+.51/- .38mm)
- Length increase when flattened* . . . . . 0.008" (.20mm) per inch

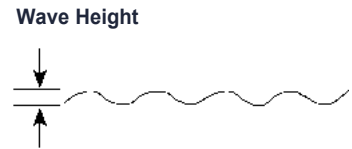
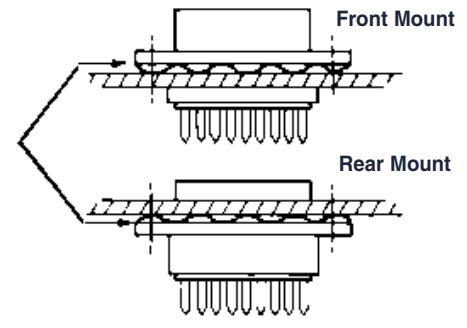

## Waved Metal Gaskets (Select part number by filling in "xxx": 572019-00xxx-70)

Mounting: Front mounted pin or socket connector, rear mounted pin connector.								
Shell Size	A ±.020 (0.51)	B ±.020 (0.51)	C ±.020 (0.51)	D ±.020 (0.51)	E ±.005 (0.13)	"xxx"		
9	1.213 (30.81)	.984 (24.99)	.777 (19.74)	.600 (15.24)	.440 (11.18)	100		
15	1.541 (39.14)	1.312 (33.32)	1.105 (28.07)	.600 (15.24)	.440 (11.18)	101		
25	2.088 (53.04)	1.852 (47.04)	1.645 (41.78)	.600 (15.24)	.440 (11.18)	102		
37	2.729 (69.32)	2.500 (63.50)	2.293 (58.24)	.600 (15.24)	.440 (11.18)	103		
50	2.635 (66.93)	2.406 (61.11)	2.190 (55.63)	.710 (18.03)	.550 (13.97)	104		
Mounting: Rear mounted socket connectors only.								
Shell Size	A ±.020 (0.51)	B ±.020 (0.51)	C ±.020 (0.51)	D ±.020 (0.51)	E ±.005 (0.13)	F ±.005 (0.13)	G ±.020 (0.51)	"xxx"
9	1.213 (30.81)	.984 (24.99)	.450 (11.43)	.660 (16.76)	.324 (8.23)	.360 (9.14)	.600 (15.24)	105
15	1.541 (39.14)	1.312 (33.32)	.670 (17.02)	.988 (25.10)	.324 (8.23)	.360 (9.14)	.600 (15.24)	106
25	2.088 (53.04)	1.852 (47.04)	1.110 (28.19)	1.528 (38.81)	.324 (8.23)	.360 (9.14)	.600 (15.24)	107
37	2.729 (69.32)	2.500 (63.50)	1.550 (39.37)	2.176 (55.27)	.324 (8.23)	.360 (9.14)	.600 (15.24)	108
50	2.635 (66.93)	2.406 (61.11)	1.550 (39.37)	2.082 (52.88)	.436 (11.07)	.470 (11.94)	.710 (18.03)	109

