

## Protecting sensitive electronics power circuits from EMI; designing for performance and size.



### Abstract

Electromagnetic interference (EMI) and the many ways it can be conducted and/or radiated in modern electronics systems is an ongoing battle with increasing stakes. The latest electronics for military, aerospace, and industrial applications are responsible for providing vital sensor insights, control/actuation, and remote monitoring of critical infrastructure, machines, and systems. A common denominator for all of these systems is the use of electrical power. This power can be easily corrupted by EMI from external sources as well as a system's own electronics, motors, switching power supply, and functions. Increased digitization and reliance on wireless communications and sensing systems are only enhancing the EMI vulnerabilities of the latest electronic systems. To protect these sensitive systems from intentional and unintentional interference engineers are employing innovative powerline filtering technology which includes new form factors and methods.

This whitepaper reviews some of the current trends in military, aerospace, and industrial systems that are increasing the threat from EMI, examines the various EMI sources, their prevalence, and the ways they can affect system function and performance, and explains how innovations in powerline filter technology can provide effective EMI protection in form factors that meet the space constraints of modern systems.

### EMI Trends Military, Aerospace, and Industrial

Previous eras relied on analog and mechanical control and sensing technology that was designed to be relatively high power and robust to external interference. However, these methods of sensing, communication, and control presented their own limitations. In current systems analog and mechanical technologies have given way to digital control, communication, and storage, as well as higher frequency RF/microwave/millimeter-wave technology for long-range communication and sensing. Recent years have seen an explosion of wireless sensing and communication technologies used in military, aerospace, and industrial applications alongside a boom in digitization of previously analog systems. The advantages of greater digital storage, processing, and control of information at the edge is continuing to drive the integration of advanced digital electronics into virtually all critical systems.

***“Recent years have seen an explosion of wireless sensing and communication technologies used in military, aerospace, and industrial applications alongside a boom in digitization of previously analog systems.”***

These advanced digital and RF systems that are vastly more capable and complex than previous generations due to higher levels of integration and smaller form factors. But they are also significantly more sensitive to electromagnetic interference (EMI) than their predecessors. And the complex power systems needed to support these new electronics also generate greater electromagnetic interference, over a far wider bandwidth, than ever before.

A good example of this is the huge increase in wireless communication components and systems within avionic and aerospace platforms to support passenger Wi-Fi, entertainment, satellite communications, intercoms, lighting, sensing, and monitoring. In addition to adding new functionality these links replace costly, heavy, and space-consuming digital/RF interconnects and cabling, leading to lighter and less costly aircraft/airframes. However, these high reliability wireless communication links and the necessary digital/RF systems to support them can also be sources of high EMI.

Another example is the increasing use of high-performance field-programmable gate arrays (FPGAs) for control systems and communication systems. Modern, high-performance FPGAs typically have a variety of different power inputs with varying voltage, current, and power quality requirements. This is also the case for more recent systems-on-chip (SoCs) and systems-in-package (SiP) microprocessor units (MCUs), single-board computers, and RF/microwave systems. Powering these electronic devices with such a variety of power input requirements necessitates the use of many switching power supplies, each with their own complex control system, to ensure that these power-hungry digital monstrosities operate as efficiently as possible.

Another trend is the shift to higher RF/microwave/mm-Wave frequencies to avoid spectrum congestion at lower frequencies, enhance sensing performance, and enable higher throughput communications over wireless links. To overcome atmospheric attenuation and still ensure long range operation at these frequencies complex active antenna systems (AAS), such as active electronically scanned antenna arrays (AESAs), and high-power microwave/mm-Wave gallium nitride (GaN) power amplifiers. Both AAS and GaN PAs require higher power inputs and generate/emit substantial microwave/mm-Wave energy and require extensive interconnect routing of high frequency signals.



***“Advanced digital and RF systems are significantly more sensitive to electromagnetic interference (EMI) than their predecessors.”***

## **Modern EMI Sources**

All the trends and observations previously mentioned have the potential to result in additional EMI generators, sources, and considerations. EMI is generally classified into two types, radiated, and conducted EMI. Radiated EMI is that which has energy contained in fields external to a conductor and can couple via capacitive, magnetic, or electromagnetic into or out of a device. Conducted EMI is EMI energy that is passed along conductors. The following is a brief discussion of the various EMI sources that are common to modern military, aerospace, and industrial electronics.

## **Power Supply Noise**

The increase of digital and RF systems replacing mechanical, analog, and traditional AC power systems is driving the use of additional DC-DC converters to power these new systems. The highly integrated digital and RF electronics often require several high-quality voltage rails. Powering these new devices may also be accomplished with the use of a series of power converters, such as a switching power converter with an AC input, such as a flyback or resonant LLC topology, or a high voltage DC input with a flyback or buck/boost topology.



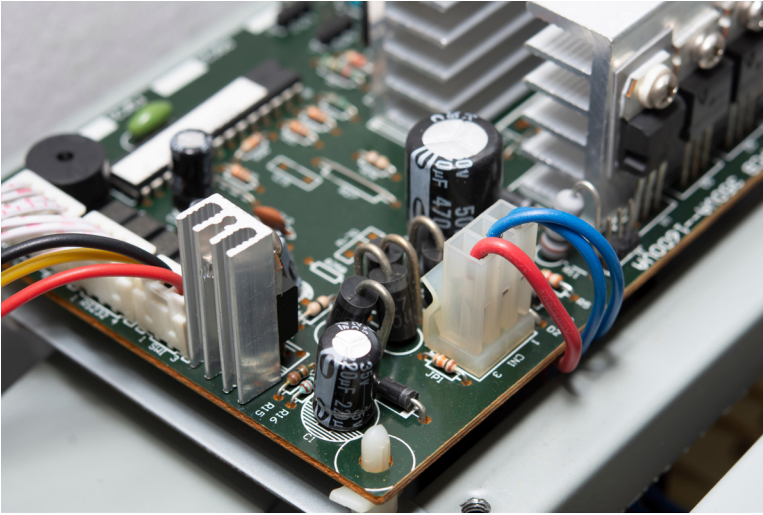

The latest power supplies for modern devices often have multiple voltage rails with a precisely designed transient response to achieve optimal efficiency. Accomplishing this generally requires switching power supplies, which now switch at much faster rates than legacy power supplies. These new switching power supplies can involve switching frequencies from over 100 kilohertz (KHz) to several megahertz (MHz), or even higher. The rapid switching speeds and on-off profile of these power supplies can generate substantial high frequency EMI that is both conducted and radiated. Though there are switching power supply topologies, such as quasi-resonant and resonant topologies, that help to minimize high frequency EMI generation from the latest power supplies, their implementation is generally more complex and does not completely solve the problem.

## Differential Powerline Noise

Though AC-DC and DC-DC converters can themselves generate EMI, noise and EMI can also be conducted to these components, and even through these components, from the utility powerline. Many utility power lines have one or more hot, neutral, and ground conductor(s). In some cases, there may be noise across all the conductors, this is known as common mode noise. But in the case of differential powerline noise, this noise is across the different conductors in a utility power line. Most powerline noise is caused by arcing across powerline hardware somewhere in the transmission path. This occurs when the conditions are right to cause ionization of the air between two conductors with significant enough electrical potential difference.



These arcs travel the transmission line and accumulate, resulting in differential powerline noise delivered to electrical devices connected to the grid. This noise can be a significant EMI source, as common-mode noise from this source is relatively easy to account for, however, differential powerline noise has a higher likelihood to impact the performance of power converters/supplies and other downstream electronics. This is due to the noise being referenced across two different potentials feeding a device and in series with the power feed. To effectively filter this noise filtering must occur in line with the power signal. In industrial settings or locations with a dense amount of high- powered equipment connected to the grid, powerline noise can even be generated by the equipment and systems connected to the grid.

## Actuator Noise

A common form of EMI in industrial settings, aerospace, and electric vehicle (EV) systems is actuator noise. Actuator noise is generated by the operation of electrical actuators or actuators that make-or-break electrical connections. Examples of actuators include electrical motors, electrical hydraulic (electro-hydraulic) systems, and electrical switches/relays. The type of noise generated by actuators and the power distribution of these EMI sources over frequency depends on the actuator's behavior which, in the case of an electrical motor, often depends on its speed, design, and motor driver type/function.



In the case of high-speed motors with sophisticated motor control systems that operate at high speeds and high frequencies, the radiated emissions created by actuator noise can reach high frequencies and then couple into a variety of systems. Also, there are many actuator systems with extremely high power levels that can store a large amount of energy in electric or magnetic fields. When sudden changes in motion or operation occur, high-powered electrical actuators can create substantial arcing and both electric and magnetic flux. This can lead to actuator noise being conducted through electrical systems directly connected to the actuator. This radiated noise can affect both nearby systems and far-away systems.

***“Sudden changes in motion or operation common in industrial motors can conduct actuator noise through electrical systems affecting both nearby and far-away systems.”***

## **Common Mode Noise in Digital Systems**

Common mode noise (CMN), also often referred to as common mode voltage (CMV) in electronic systems, is the identical noise present at the input of a circuit referenced to the circuit ground. In the case of digital circuits, this can be the noise at the input of an Analog-to-Digital converter (ADC), a digital-to-analog converter (DAC), the inputs of a digital communication system, or the inputs of a memory/storage device. In the case of modern electronic systems, there may be a variety of grounds and complex routing of ground leads that can lead to a difference in potential between two physically remote grounds. This phenomenon is extremely common in computer networking systems, where the complex routing and multiple interconnects makes ground loops relatively common.

Common mode noise can be incredibly disruptive to digital systems with sensitive inputs and could lead to corrupted data transfers, reboots, and even error conditions resulting in lockups. Given the high number of power and signal inputs into high performance digital systems, such as FPGAs, MCUs, GPUs, DSPs, and ASICs, these systems, along with common networking devices, such as modems, routers, switches, and network interfaces in computers, are extremely susceptible to common-mode noise. Additionally, common mode noise can lead to radiated EMI. For this reason, many modern circuit design suites and board layout software can solve for radiated emissions from common mode noise.



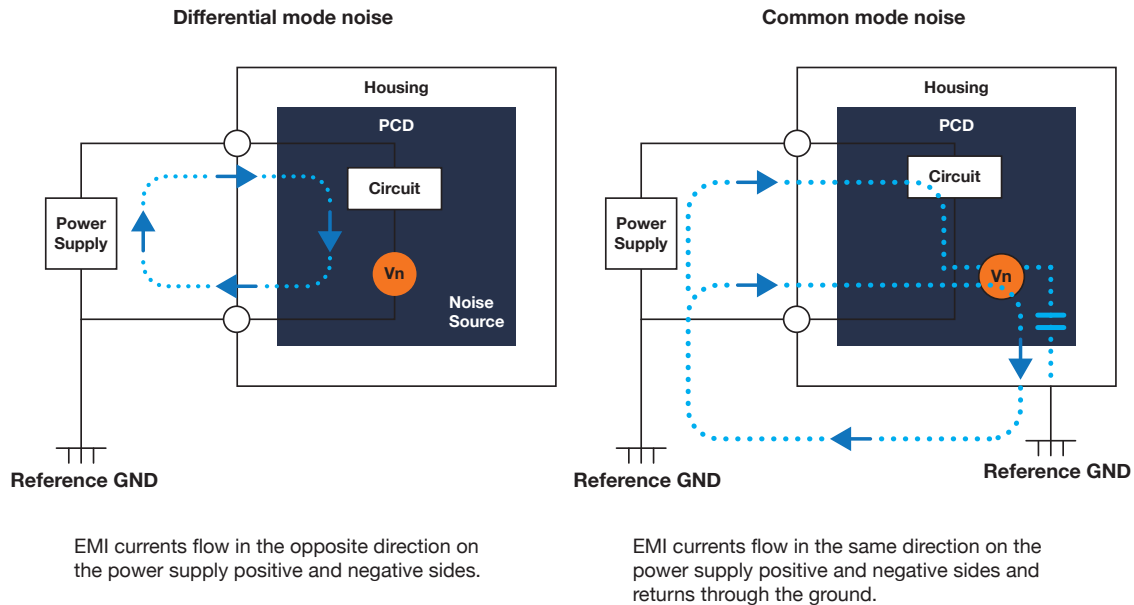

**Figure 1:**  
Differential (normal) mode noise and common mode noise.

## High Intensity Radiated Fields (HIRF)

High Intensity Radiated Fields (HIRF) are a classification of EMI of particular concern to military and commercial aviation. Specifically, there are a wide array of HIRF testing and standards levels required by governments and aircraft manufacturers to ensure aircraft can operate safely even in an environment of potentially dangerous HIRF. The concern, specifically for aircraft, is that they are intrinsically critical systems and may be subjected to extreme electromagnetic environments, either from man-made or natural sources.

### HIRF Testing Requirements by Various Agencies

*FAA HIRF Rule and AC 20-158, ALL CW, SW, and Pulse test levels, for ALL Environments*

*RTCA/DO-160D/E/F/G, ALL CW, SW, and Pulse test levels, for all Categories, including Cat. L*

*Boeing D6-16050-4/-5/-6, ALL CW, SW, and Pulse test levels*

*Airbus ABD0100.1.2, Rev E/F/G, ALL CW, SW, and Pulse test levels*

*MIL-STD-464A/C, ALL CW, SW, and Pulse test levels*

*ADS-37A-PRF, Table I, Part A & B, ALL CW, SW, AM, FM, and Pulse test levels*

*Def-Stan 59-41 & 59-411 DRS02.B, ALL Air, Sea and Land CW, SW, AM and Pulse Levels*

***“Testing and standard levels are required by governments and aircraft manufacturers to ensure aircraft can operate safely in an environment of potentially dangerous HIRF.”***

As a result of a variety of trends in aviation electronics and aircraft manufacturing, concern over the safety of aircraft electrical and electronic systems is growing. Some of these additional considerations include the increased use of composite materials that afford lower levels of electromagnetic shielding than prior structural materials, and the much greater use of electrical and electronic systems critical to aircraft flight, sensing, communication, and landing functions.



## HIRF Frequency Band Classifications

10 kHz to 50 MHz: Low frequency HIRF which may result in inducing currents in the communication antenna and the aircraft fuselage skin, but otherwise demonstrate little interior penetration.  
20 MHz and 400 MHz: Medium frequency HIRF, with the combined effects of High Frequency HIRF and Low Frequency HIRF, which may produce antenna-like behavior and some fuselage penetration.  
100 MHz to 18/40 GHz: High Frequency HIRF may generate strong fields penetrating the fuselage and endangering critical internal electrical and electronic systems.

***“The most common natural EMI of concern to most military, industrial, and aerospace systems is direct or nearby lightning strikes.”***

### Naturally Occurring

Lastly, there is naturally occurring EMI, which can be produced by both terrestrial and space weather, and other natural phenomena. Even earth’s atmospheric conditions, volcanic eruptions, and solar storms or ejections can result in naturally occurring EMI that impacts electrical and electronic systems on earth over vast regions. However, the most common natural EMI of concern to most military, industrial, and aerospace systems is either direct lightning strikes or nearby lightning strikes.

Lighting is highly transient even with potentially very high voltage/current/power levels being conducted into the electric grid, electrical systems, and electronic systems.

The energy generated from a lightning strike is generally below 10 MHz and this only couples efficiently into larger electrical systems and long conductors. However, these conductors can readily conduct surges from radiated or conducted lightning strike energy into electrical/electronic power lines and systems. Though there are often lightning arrestors and surge protectors installed in many buildings and installations, these forms of protection don’t always stop all of the EMI generated from lightning strikes, especially considering that some storms can result in a high number of lightning strikes to occur over extended periods of time.

### Harnessing Innovation to Tackle Modern EMI Challenges

Given the myriad forms of EMI and greater susceptibility of modern electrical and electronic systems to electromagnetic interference, EMI filters are necessary for virtually all critical applications. Filter location and performance are of vital importance for ensuring EMI isn’t conducted into a device or system and EMI-generated within a device or system isn’t conducted out of that device or system. However, EMI filters, like any component added to a bill-of-materials (BOM), increases cost, takes up space, introduces one or more points of failure, and will likely require some type of qualification and documentation.



In the case of unmanned aerial vehicles (UAVs), aircraft, land mobile vehicles, and manpack systems, any additional weight or space can have significant ramifications on the performance of the mobile systems. Moreover, portable or modular equipment, for military and industrial applications, which ideally serves to optimize cost vs. performance, is also limited in the amount of viable space and often weight.

Hence, a solution is needed that includes all of the capabilities of a robust and capable power line EMI filter in a footprint and platform that minimizes the size and weight of EMI filtering without sacrificing performance. This presents a substantial engineering challenge that requires an innovative solution, especially considering that both common-mode and differential mode filtering is necessary for most modern electronic systems.

## Benefits of Combining a Connector With an EMI Filter

A solution to this challenge is to integrate power line filter technology directly into a power entry connector. A power entry connector, such as a MIL-DTL-38999, provides a bulkhead power connection between the housing of a device/system, often metal shielding, to the internal components. A typical power entry filter is a separate component with metallic housing and leads and requires adequate mounting space and thermal management. By combining the connector with a power line filter, many components are eliminated and other advantages are gained.

With a combined connector and power filter, the leads that would interconnect the power connector and power entry filter are internal to the power filter connector. This eliminates the need to purchase and connect this additional wiring when assembling a device or system, and also removes the potential that any EMI conducted into the device from the power connector would then be radiated within the device or system. Less interconnect and components within a system reduces failure points, simplifies assembly, eases maintenance/operational expenditures (OPEX), and reduces the need to qualify and trace a separate power entry filter.

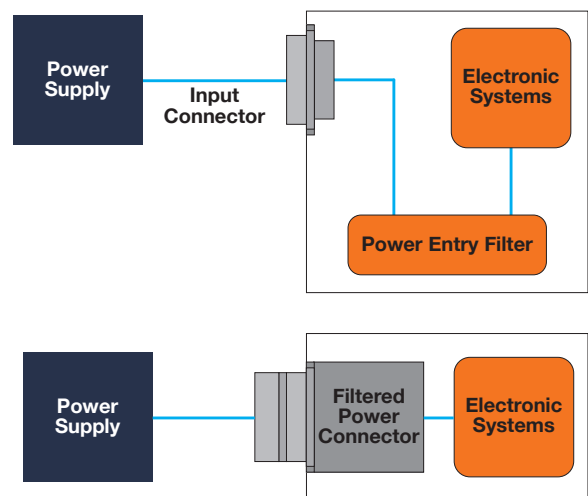

Traditionally, connectors that are filtered only provide common mode noise reduction at 1Mhz and higher. This is a result of the lack of significant inductance under load and line to line capacitance. Though adequate for most signal line applications, this arrangement isn't suited for power lines. Spectrum Controls's novel integrated Power Line Filter Connector solves this problem and provides both common mode noise and differential mode noise reduction down to 100KHz.

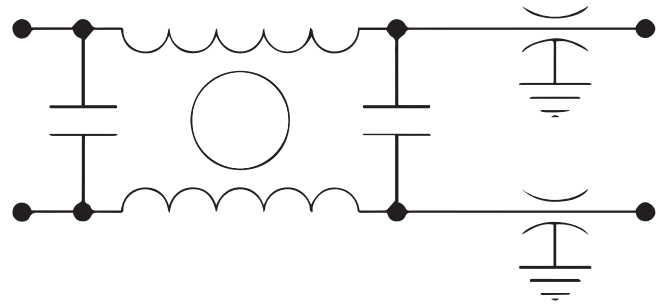

**Figure 2:**

Image of an EMI Filter Power Line Connector and representative schematic shown above.

## Conclusion

Protecting modern electronics systems from electromagnetic interference requires both best-in-class filtering and innovative packaging that can meet the size constraints of these miniaturized systems. A power connector with an integrated power line filter is such an innovation with the potential to address the many and various EMI threats. EMI Filter Power Line Connectors from Spectrum Control offer superior protection in a small-footprint package incorporating Spectrum Control's unique RF geometry ceramic capacitor technology and novel broadband magnetic designs to achieve both common and differential mode circuit protection. They are designed to operate across a broad spectrum of both frequency and power. The innovative, small footprint connector package makes it easy to incorporate EMI protection into existing or new designs.

## Resources

1. Aircraft EMI Shielding Market- Industry Analysis and Forecast (2022-2027) by Aircraft Type, Application Type, Product Type, Location Type and Region
2. Global EMI and EMC Filters Market Growth 2021-2026
3. EMI Shielding Market: Global Industry Trends, Share, Size, Growth, Opportunity and Forecast 2022-2027
4. Defense Market Trends and the Impact on Semiconductor Technology