

REVISIONS				
ECN	REV.	DESCRIPTION	CHNG/DATE	APPVD/DATE
XXX	P1	PRELIMINARY RELEASE	2013-06-24	

NOTES:

- 1. HOUSING: 70/30 CU/NI ELECTRONIC GRADE

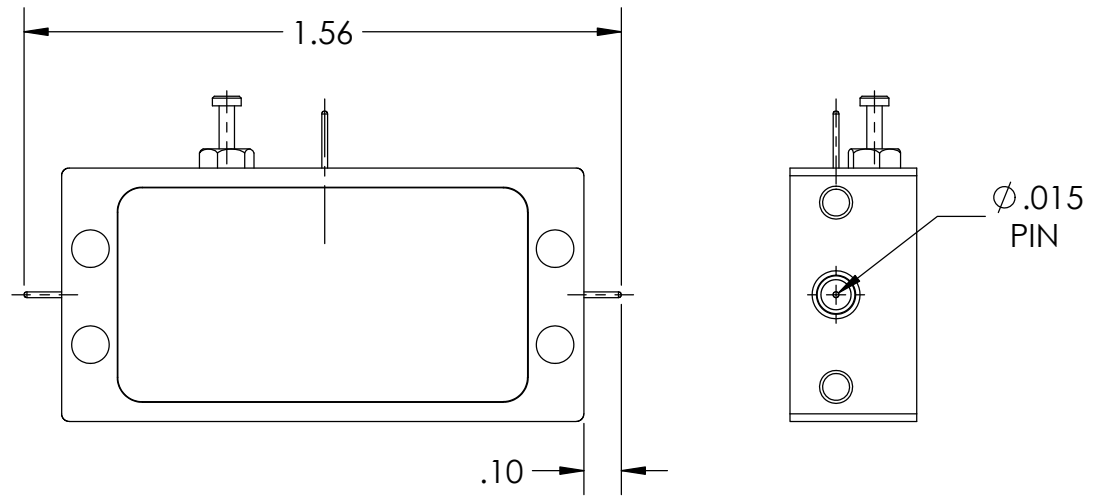
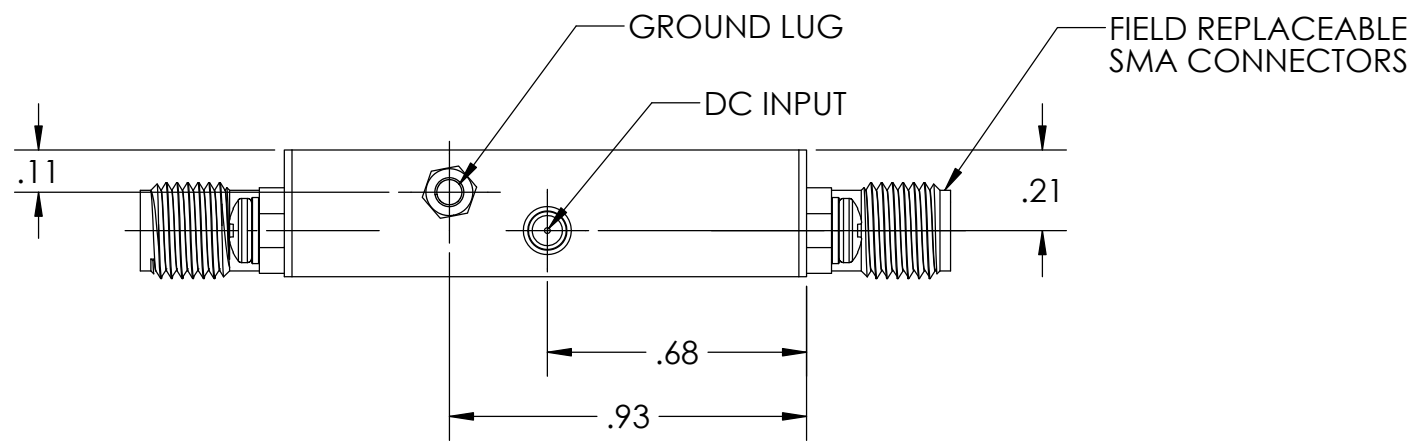

**WITHOUT SMA CONNECTOR**

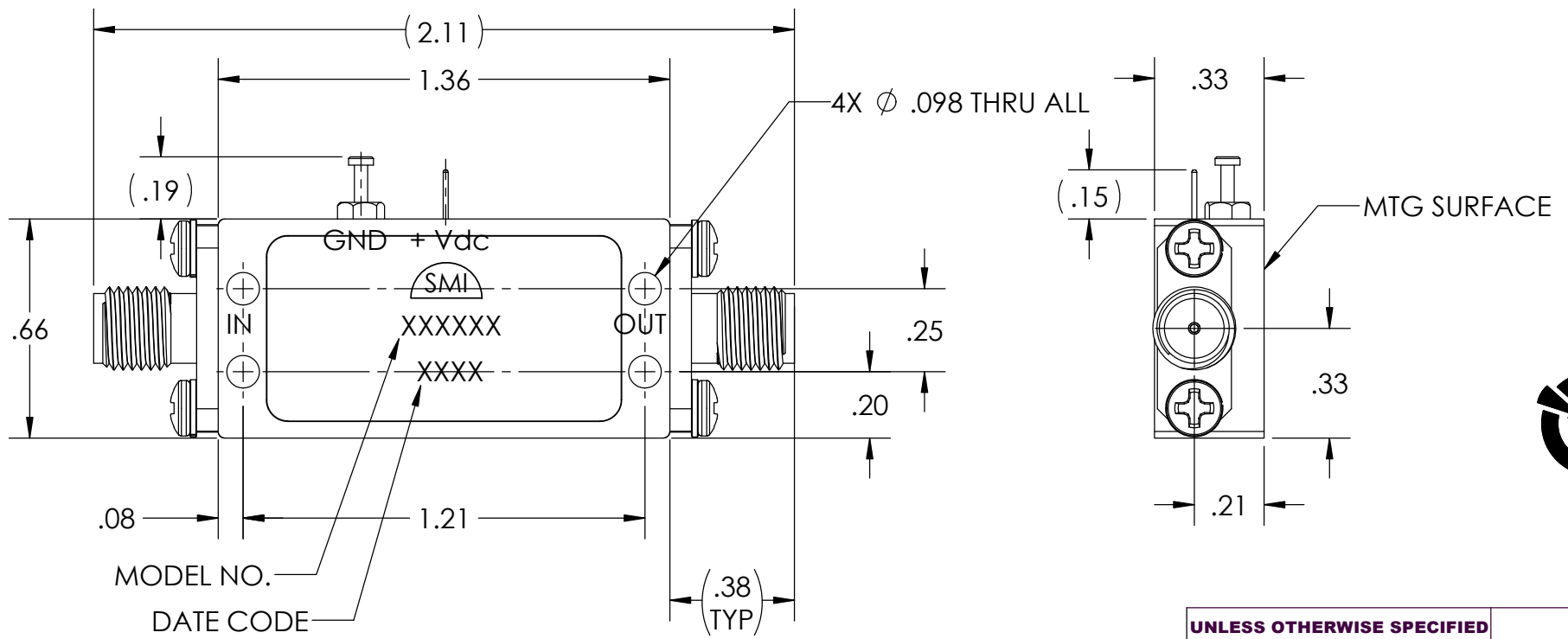

**CAUTION**

**THIS ASSEMBLY CONTAINS PARTS SENSITIVE TO DAMAGE BY ELECTROSTATIC DISCHARGE (ESD). USE ESD PRECAUTIONARY PROCEDURES WHEN TOUCHING, REMOVING OR INSERTING**

SEE SEPARATE PARTS LIST IN ELECTRONIC STORAGE

A

A

B

B

**SPECTRUM MICROWAVE PROPRIETARY INFORMATION**  
 THIS DOCUMENT IS THE SOLE PROPERTY OF SPECTRUM MICROWAVE, INC. THE RELEASE OF DATA CONTAINED IN THIS DOCUMENT AND THE REPRODUCTION OF THIS DOCUMENT, IN WHOLE OR IN PART, WITHOUT THE WRITTEN PERMISSION OF SPECTRUM MICROWAVE, INC ARE PROHIBITED.

<b>UNLESS OTHERWISE SPECIFIED</b>		3rd ANGLE PROJECTION	
* INTERPRET DRAWING IAW ASME Y14.100-2004		ANSI	
* DIMENSIONING AND TOLERANCING IAW ASME Y14.5-1994		DRAWN	DATE
* PARENTHETICAL INFORMATION FOR REFERENCE ONLY		WAR	2013-06-24
* DIMENSIONAL LIMITS APPLY BEFORE PROCESSES		CHECKED	
* DIMENSIONS ARE IN INCHES		ENGRG	
* TOLERANCES ARE: ANGLES ±1.0°		HP	2013-06-24
* SURFACE FINISH $63 \sqrt{\text{2 PLACE DECIMAL } \pm .02}$		MFG	
* REMOVE ALL BURRS AND SHARP EDGES .010 RAD MAX.		QA	
* CONCENTRICITY MACHINED DIA: .002 FIM			
* MACHINED TOOL MISMATCH: .002 MAX.			
<b>DO NOT SCALE DRAWING</b>			

<b>SPECTRUM MICROWAVE, INC</b>			
2707 Black Lake Place			
Philadelphia, PA 19154-1008 (USA)			
TITLE			
<b>OUTLINE, H2L</b>			
SIZE	CAGE CODE	DWG NO.	REV
<b>B</b>	<b>60979</b>	<b>088-00387</b>	<b>P1</b>
SCALE:		SHEET	
<b>2:1</b>		<b>1</b>	<b>OF 1</b>