

OTL23100003

REVISIONS

LTR	DESCRIPTION	DATE	APPROVED
B	ECN 3654, UPDATE ALL, SIGN-OFF	10/10/90	JR 2/22/91
C	ECN 11113, REDRAWN ON CAD	11/21/01	

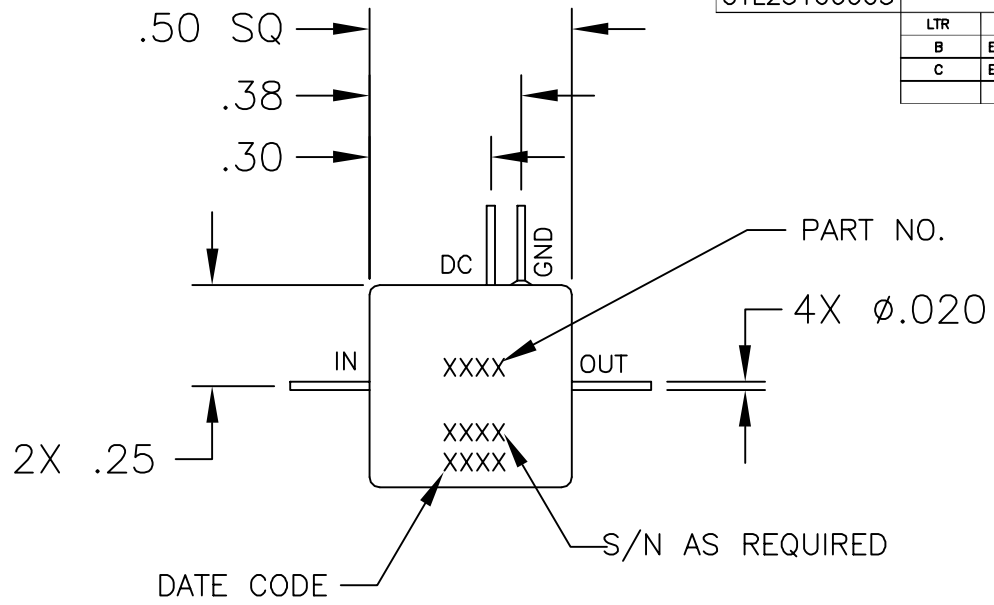

MATERIAL: KOVAR
FINISH: NICKEL/GOLD

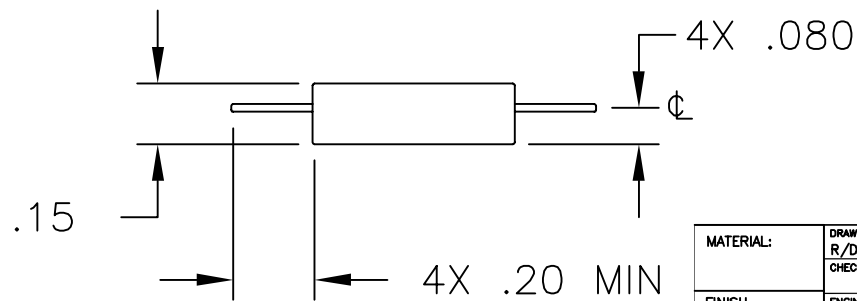

CAUTION
THIS ASSEMBLY CONTAINS PARTS SENSITIVE TO DAMAGE BY ELECTRO-STATIC DISCHARGE (ESD). USE ESD PRECAUTIONARY PROCEDURES WHEN TOUCHING, REMOVING OR INSERTING.

MATERIAL:	DRAWN	DATE	2707 BLACK LAKE PLACE, PHILADELPHIA PA. 19154
	R/D ADAM SIDLE	11/21/01	
FINISH	CHECKED	DATE	OUTLINE DRAWING FP-4
	ENGINEERING ARR	11/17/90	
DIMENSIONS: INCHES	MANUFACTURING	DATE	CODE IDENT NO. 60979 OTL 23100003
	TOLERANCE	QUALITY	
DEC.	.XX +/- .01	JR	11/17/90
	.XXX +/- .005		